



## Grooving cutterhead set adjustable with spacers

### Application:

For cutting different groove widths.

### Machine:

Spindle moulders, moulders, edgbanding machines and stationary routers with/without CNC control, double-end tenoners.

### Workpiece material:

Solid wood along grain and across grain; uncoated, coated and veneered wood derived materials in top layer and middle layer.

### Technical information:

Adjustment of cutting widths with spacers (adjustment 0.10 mm).



### 2 part; SB 4.0 - 7.5 mm

SW 501 1 01

D	SB	BO	BO <sub>max</sub>	NT	Z	n	ID
mm	mm	mm	mm	mm		min <sup>-1</sup>	
150	4.0 - 7.5	30	50	20	2/2	5200 - 10100	<b>128100 ●</b>
180	4.0 - 7.5	30	50	35	2/2	4300 - 8400	<b>128101 ●</b>

### Extension parts SB 3.8 mm

WW 200 1 NN

D	SB	BO	BO <sub>max</sub>	Z	n	ID
mm	mm	mm	mm		min <sup>-1</sup>	
150	3.8	30	50	2	5200 - 10100	<b>128130</b>
180	3.8	30	50	2	4300 - 8400	<b>128131</b>

Each extension part increases the cutting widths by 3.6 mm.

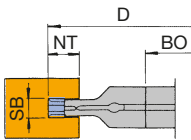
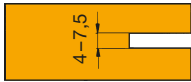

Grooving cutterhead set, 2 part design

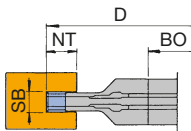
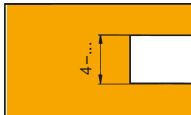

Grooving cutterhead set, multi part design

### Spare knives:

Part-no.	BEZ	ABM	QAL	VE	ID
		mm		PCS	
1	Turnblade knife	18x18x1.95	HW	10	<b>005114 ●</b>
2	Turnblade spur VS4	14x14x1.2	HW	10	<b>005130 ●</b>

### Spare parts:

Part-no.	BEZ	ABM	ID
		mm	
3	Special nut for VS	M9.9/1.60	<b>005654 ●</b>
4	Special nut for WPL	M11.9/2.20	<b>005653 ●</b>
5	Countersink screw, Torx® 9	M4x0.5x3.2	<b>006057 ●</b>
6	Torx® key	Torx® 9	<b>005463 ●</b>
	Setting gauge for knives	0.3/0.8	<b>005374 ●</b>

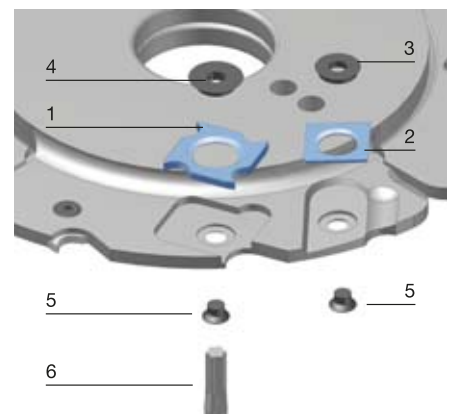

Архангельск (8182)63-90-72  
Астана (7172)727-132  
Астрахань (8512)99-46-04  
Барнаул (3852)73-04-60  
Белгород (4722)40-23-64  
Брянск (4832)59-03-52  
Владивосток (423)249-28-31  
Волгоград (844)278-03-48  
Вологда (8172)26-41-59  
Воронеж (473)204-51-73  
Екатеринбург (343)384-55-89  
Иваново (4932)77-34-06

Ижевск (3412)26-03-58  
Иркутск (395)279-98-46  
Казань (843)206-01-48  
Калининград (4012)72-03-81  
Калуга (4842)92-23-67  
Кемерово (3842)65-04-62  
Киров (8332)68-02-04  
Краснодар (861)203-40-90  
Красноярск (391)204-63-61  
Курск (4712)77-13-04  
Липецк (4742)52-20-81  
Киргизия (996)312-96-26-47

Магнитогорск (3519)55-03-13  
Москва (495)268-04-70  
Мурманск (8152)59-64-93  
Набережные Челны (8552)20-53-41  
Нижний Новгород (831)429-08-12  
Новокузнецк (3843)20-46-81  
Новосибирск (383)227-86-73  
Омск (3812)21-46-40  
Орел (4862)44-53-42  
Оренбург (3532)37-68-04  
Пенза (8412)22-31-16  
Россия (495)268-04-70

Пермь (342)205-81-47  
Ростов-на-Дону (863)308-18-15  
Рязань (4912)46-61-64  
Самара (846)206-03-16  
Санкт-Петербург (812)309-46-40  
Саратов (845)249-38-78  
Севастополь (8692)22-31-93  
Симферополь (3652)67-13-56  
Смоленск (4812)29-41-54  
Сочи (862)225-72-31  
Ставрополь (8652)20-65-13  
Казахстан (772)734-952-31

Сургут (3462)77-98-35  
Тверь (4822)63-31-35  
Томск (3822)98-41-53  
Тула (4872)74-02-29  
Тюмень (3452)66-21-18  
Ульяновск (8422)24-23-59  
Уфа (347)229-48-12  
Хабаровск (4212)92-98-04  
Челябинск (351)202-03-61  
Череповец (8202)49-02-64  
Ярославль (4852)69-52-93



## Grooving cutterhead set adjustable with spacers

### Application:

For cutting different groove widths.

### Machine:

Spindle moulders, moulders, edgbanding machines and stationary routers with/without CNC control, double-end tenoners.

### Workpiece material:

Solid wood along grain and across grain; uncoated, coated and veneered wood derived materials.

### Technical information:

Adjustment of cutting widths with spacers (adj. range 0.1 mm). Multi part design.

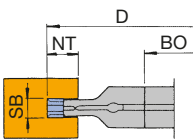
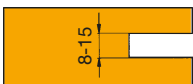

Grooving cutterhead set, 2 part design

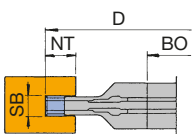
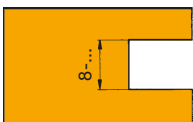

Grooving cutterhead set, multi part design

### Multi part; SB 8.0 - 30.0 mm

SW 501 1, SW 501 1 01

D	SB	BO	NT	Z	n	ID
mm	mm	mm	mm		min <sup>-1</sup>	
150	8.0 - 15.4	30	20	2/2	5200 - 10100	<b>128104</b> ●
180	8.0 - 15.4	30	35	2/2	4300 - 8400	<b>128105</b> ●
200	8.0 - 15.4	30	45	2/2	3900 - 7600	<b>128106</b> ●
220	8.0 - 30.0	30	58	2/2	3500 - 6000	<b>024663</b> ●

### Extension part

SW 501 1, WW 200 1 NN

D	SB	BO	BO <sub>max</sub>	Z	n	ID
mm	mm	mm	mm		min <sup>-1</sup>	
150	7.7	30	50	2	5200 - 10100	<b>128134</b>
180	7.7	30	50	2	4300 - 8400	<b>128135</b> ●
200	7.7	30	50	2	3900 - 7600	<b>128136</b> ●
220	15	30	45	2	3500 - 6000	<b>024666</b> ●

### Spare knives:

Part-no.	BEZ	ABM	QAL	VE	ID
		mm		PCS	
1	Turnblade knife	7.7x8x1.5	HW-05	10	<b>005053</b> ●
1	Turnblade knife	14.7x8x1.5	HW-05	10	<b>005056</b> ●
2	Turnblade spur VS1	14x14x2	HW-F	10	<b>005099</b> ●
2	Turnblade spur VS2	19x19x2	HW-F	10	<b>005115</b> ●

### Spare parts:

Part-no.	BEZ	ABM	ID
		mm	
3	Clamping wedge	7x18.75x8.27	<b>009763</b> ●
3	Clamping wedge	13x18.75x8.27	<b>009670</b> ●
4	Allen screw with shank, Torx® 15	M5x20	<b>007380</b> ●
4	Clamping screw w. disc, Torx® 25	M6x18.5	<b>007442</b> ●
5	Torx® key	Torx® 15	<b>117507</b> ●
5	Torx® key	Torx® 25	<b>117504</b> ●
6	Countersink screw, Torx® 20	M6x0.5x4.9	<b>006243</b> ●
7	Torx® key	Torx® 20	<b>117503</b> ●
	Setting gauge for knives	0.3/0.8	<b>005374</b> ●

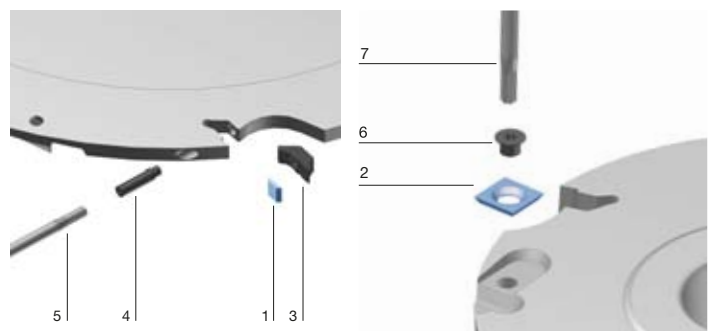

### 3. Planing and profiling

### 3.2 Planing 3.2.1 Cutterheads for pre-planing



#### Cutterhead for groove bed guide

**Application:**

For guide grooves on the first bottom spindle for precise feeding of short parts or curved workpieces.

**Machine:**

Four-sided moulders with groove beds.

**Workpiece material:**

Softwood and hardwood, along grain.

**Technical information:**

Build up turnblade knife tool system, diameter and cutting width constant. The closed, round design of the tool body reduces the noise level.

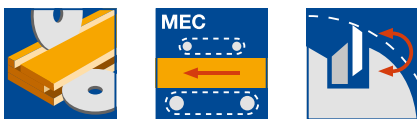

**HW turnblade design**

WW 101 2, WW 102 2

D	SB	BO	BO <sub>max</sub>	Z	V	n <sub>max</sub>	ID
mm	mm	mm	mm			min <sup>-1</sup>	
125	20	40	50	2	2	12000	<b>020389 ●</b>
125	10	40	50	2	2	12000	<b>020390 ●</b>
140	20	40	50	2	2	10900	<b>020386 ●</b>
140	10	40	50	2	2	10900	<b>020388 ●</b>

**Spare knives:**

BEZ	ABM	QAL	VE	ID
	mm		PCS	
Turnblade knife	19.7x8x1.5	HW-30F	10	<b>005071 ●</b>
Turnblade knife	9.7x8x1.5	HW-30F	10	<b>005197 ●</b>
Turnblade spur VS1	14x14x2	HW-F	10	<b>005099 ●</b>

**Spare parts:**

BEZ	ABM	ID
	mm	
Spacer	60x0.1x40	<b>027941 ●</b>
Spacer	60x0.3x40	<b>027942 ●</b>
Spacer	60x9x40	<b>028449 ●</b>
Spacer	60x10x40	<b>027951 ●</b>
Clamping wedge	18x18.75x8.27	<b>009671 ●</b>
Clamping wedge	9x18.75x8.27	<b>009764 ●</b>
Clamping screw w. disc, Torx® 25	M6x18.5	<b>007442 ●</b>
Allen screw with shank, Torx® 15	M5x20	<b>007380 ●</b>
Countersink screw, Torx® 20	M6x0.5x4.9	<b>006243 ●</b>
Torx® key	Torx® 15	<b>117507 ●</b>
Torx® key	Torx® 20	<b>117503 ●</b>
Setting gauge for knives	0.3/0.8	<b>005374 ●</b>

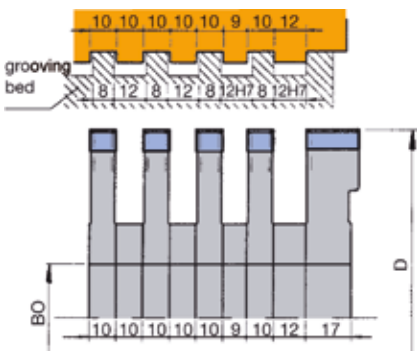

**Number of tools for different widths**

SB mm	working width mm				
	80	100	120	140	170
SB 20	1	1	1	1	1
SB 10	3	4	5	6	8

### 3. Planing and profiling

### 3.2 Planing

#### 3.2.1 Cutterheads for pre-planing



#### Planerhead HeliPlan with 4 edge HW turnblade knives

**Application:**

Pre-planing, surfacing and jointing all types of wood with large chip removal. Also suitable for finish planing if quality demands are less important or in combination with subsequent sanding.

**Machine:**

Four-sided moulders.

**Workpiece material:**

Softwood and hardwood.

**Technical information:**

Pre-planing cutterhead with 4 edge HW turnblade knives. Low noise and energy efficient due to spiral, segmented edge arrangement. Smooth finish by radiused cutting edges. Aluminium tool body. Optional with steel reference cutterhead for machines with fence.

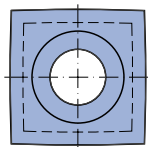
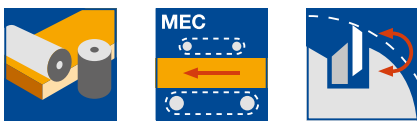

HW turnblade knife

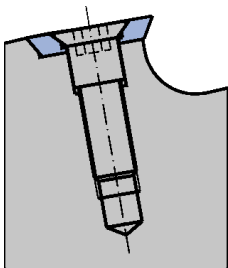

Knives mounted on periphery

**Aluminium tool body, with bore**

WW 220 2 01

D	SB	ND	BO	Z	AM	$n_{max}$	ID
mm	mm	mm	mm		PCS	$min^{-1}$	
125	130	136	40	2/2	22	12000	<b>030423 ●</b>
125	166	172	40	2/2	28	12000	<b>030467 ●</b>
125	210	216	40	2/2	36	12000	<b>030452 ●</b>
125	236	242	40	2/2	40	12000	<b>030466 ●</b>
125	256	262	40	2/2	44	12000	<b>030470 ●</b>
140	166	172	50	2/2	28	12000	<b>030468 ●</b>
140	236	242	50	2/2	40	12000	<b>030469 ●</b>

Design with HW cutting edges.

Further dimensions and inch dimensions available on request.

Suitable reference cutterheads on page 11.

**Spare knives:**

BEZ	ABM	QAL	VE	ID
	mm		PCS	
Turnblade knife	15x15x2.5	HW	10	<b>009535 ●</b>
Turnblade knife	15x15x2.5	TDC		<b>602901 ●</b>

**Spare parts:**

BEZ	ABM	ID
	mm	
Countersink screw, Torx® 20	M5x14.2-8.8	<b>007394 ●</b>
Torx® key	Torx® 20	<b>006091 ●</b>

## 4. Manual feed

## 4.2 Jointing, rebating and bevelling

### 4.2.2 Jointing and copy shaping cutterheads

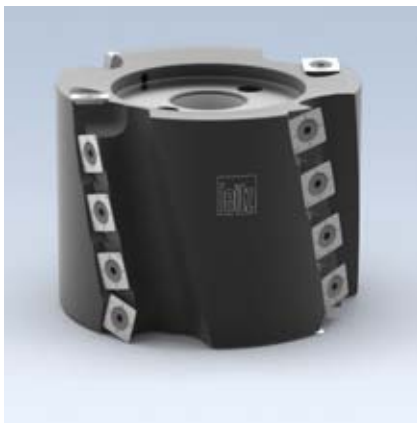

#### Copy shaping cutterhead - HeliCut 15

##### Application:

For pre-cutting, jointing and copy shaping of large cutting depths. For copy shaping of curved workpieces with template, ball bearing and guide ring.

##### Machine:

Spindle moulders and profile milling machines, double-end tenoner, stationary routers with and without CNC control.

##### Workpiece material:

Softwood and hardwood, glulam, chipboard and fibre materials (MDF etc.) uncoated, plastic coated, veneered etc.

##### Technical information:

Noise reduced design with staggered edges and very deep gullets for improved chip removal. Tungsten carbide cutting edges with Microfinish for perfect surface quality. Rebate tools cut on the periphery and the side.



#### Cutterhead for copy shaping, grooving and rebating

WW 230 2 07

D	SB	BO	Z	V	QAL	AM	ID
mm	mm	mm				PCS	
60	81.5	20	2	2	HW-MF	16	132600 ●
80	81.5	30	2	2	HW-MF	16	132608 ●
125	93.7	30	2	2+2	HW-MF	20	132604 ●
125	116.6	30	2	2+2	HW-MF	24	132605 ●

RPM: D 60 mm:  $n_{\max} = 20000 \text{ min}^{-1}$

D 80 mm:  $n_{\max} = 18000 \text{ min}^{-1}$

D 125 mm:  $n_{\max} = 12000 \text{ min}^{-1}$

##### Spare knives:

BEZ	ABM	QAL	BEM	VE	ID
	mm			PCS	
Turnblade knife	15x15x2.5	HW-MF	HeliCut 15	10	009543 ●
Turnblade knife	15x15x2.5	HW	HeliCut 15	10	009549 ●

##### Spare parts:

BEZ	ABM	for D	ID
	mm	mm	
Countersink screw, Torx® 20	M5x18	125	114030 ●
Countersink screw, Torx® 20	M5x12	60/80	007898 ●
Torx® key	Torx® 20		006091 ●

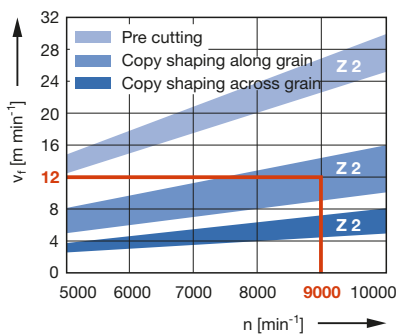

Feed speed  $v_f$  depending on the number of teeth  $Z$  and speed  $n$  for solid wood (pre trimming and copy shaping)

##### Example:

$n = 9000 \text{ min}^{-1}$ ,  $Z 2$ /copy shaping along the grain:  $v_f = 12 \text{ m min}^{-1}$



Архангельск (8182)63-90-72  
Астана (7172)727-132  
Астрахань (8512)99-46-04  
Барнаул (3852)73-04-60  
Белгород (4722)40-23-64  
Брянск (4832)59-03-52  
Владивосток (423)249-28-31  
Волгоград (844)278-03-48  
Вологда (8172)26-41-59  
Воронеж (473)204-51-73  
Екатеринбург (343)384-55-89  
Иваново (4932)77-34-06

Ижевск (3412)26-03-58  
Иркутск (395)279-98-46  
Казань (843)206-01-48  
Калининград (4012)72-03-81  
Калуга (4842)92-23-67  
Кемерово (3842)65-04-62  
Киров (8332)68-02-04  
Краснодар (861)203-40-90  
Красноярск (391)204-63-61  
Курск (4712)77-13-04  
Липецк (4742)52-20-81  
Киргизия (996)312-96-26-47

Магнитогорск (3519)55-03-13  
Москва (495)268-04-70  
Мурманск (8152)59-64-93  
Набережные Челны (8552)20-53-41  
Нижний Новгород (831)429-08-12  
Новокузнецк (3843)20-46-81  
Новосибирск (383)227-86-73  
Омск (3812)21-46-40  
Орел (4862)44-53-42  
Оренбург (3532)37-68-04  
Пенза (8412)22-31-16  
Россия (495)268-04-70

Пермь (342)205-81-47  
Ростов-на-Дону (863)308-18-15  
Рязань (4912)46-61-64  
Самара (846)206-03-16  
Санкт-Петербург (812)309-46-40  
Саратов (845)249-38-78  
Севастополь (8692)22-31-93  
Симферополь (3652)67-13-56  
Смоленск (4812)29-41-54  
Сочи (862)225-72-31  
Ставрополь (8652)20-65-13  
Казахстан (772)734-952-31

Сургут (3462)77-98-35  
Тверь (4822)63-31-35  
Томск (3822)98-41-53  
Тула (4872)74-02-29  
Тюмень (3452)66-21-18  
Ульяновск (8422)24-23-59  
Уфа (347)229-48-12  
Хабаровск (4212)92-98-04  
Челябинск (351)202-03-61  
Череповец (8202)49-02-64  
Ярославль (4852)69-52-93