

2. Panel processing

2.1 Edge processing

2.1.2 Jointing cutters



WhisperCut jointing / milling cutter - cutterhead design

Application:

For tear-free and noise reduced jointing of workpiece cutting surfaces with and against feed (jump cutting) particularly for sensitive decorative papers, foil coatings and veneers.

Machine:

Edgebanding machines, copy shaping machines, double-end tenoners etc.

Workpiece material:

Chip and fibre boards (MDF etc.) raw, veneered, painted and coated; especially for plastic, paper, HPL and anti-fingerprint coatings. Also suitable for surfaces in mat, high gloss or with relief structures.

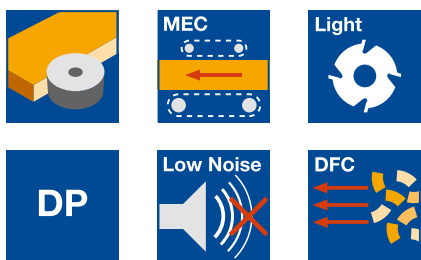

Technical information:

DP tipped cutterhead with alternate shear angle for tear-free jointing edges and cutting surface. Increased shear angle for excellent edge quality on sensitive decorative papers, foil coatings and veneers. Tool with knife arrangement S can be used lefthand and righthand and produces a hollow cut for tightly fitting edgebanding. Noise reduced design with up to 5 dB(A) noise reduction and highly efficient chip collection (>95%) through DFC. Significant weight reduction by using an aluminium alloy tool body. Carrier body for multiple use with exchangeable knives. 3.1 mm resharpening area.

Diamaster WhisperCut PLUS EdgeExpert - DFC, LowNoise, aluminium alloy tool body

WM 230 2 02

Machine	D	SB	ND	BO	NAL	n_{max}	Z	Type	ID	ID
	mm	mm	mm	mm		min^{-1}			LH	RH
Biesse	125	43	40	30 DKN	2	13700	3x6	S	192255 ●	192255 ●
Homag	125	43	40	30 DKN	2	13700	3x6	S	192255 ●	192255 ●
IMA	125	43	40	30 DKN	2	13700	3x6	AS	192256 ●	192257 ●

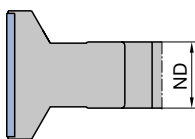

Diamaster WhisperCut rebating cutterhead

WM 430 2 01, WP 499 2

Tool Type	ABM	QAL	Z	ID
	mm			
Cutterhead	70.53x55x20	DP	3x5	192275 ●
Cutterhead mounted on arbor	D70.53/SB55	DP	3x5	192276 □

Unless stated otherwise, tools are right hand rotation.

Cutter arbor see section Clamping Systems.

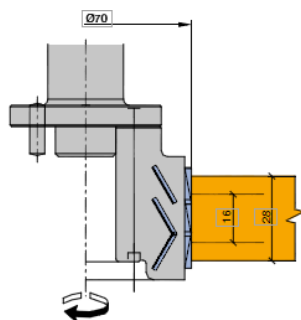

Архангельск (8182)63-90-72
Астана (7172)727-132
Астрахань (8512)99-46-04
Барнаул (3852)73-04-60
Белгород (4722)40-23-64
Брянск (4832)59-03-52
Владивосток (423)249-28-31
Волгоград (844)278-03-48
Вологда (8172)26-41-59
Воронеж (473)204-51-73
Екатеринбург (343)384-55-89
Иваново (4932)77-34-06

Ижевск (3412)26-03-58
Иркутск (395)279-98-46
Казань (843)206-01-48
Калининград (4012)72-03-81
Калуга (4842)92-23-67
Кемерово (3842)65-04-62
Киров (8332)68-02-04
Краснодар (861)203-40-90
Красноярск (391)204-63-61
Курск (4712)77-13-04
Липецк (4742)52-20-81
Киргизия (996)312-96-26-47

Магнитогорск (3519)55-03-13
Москва (495)268-04-70
Мурманск (8152)59-64-93
Набережные Челны (8552)20-53-41
Нижегород (831)429-08-12
Новокузнецк (3843)20-46-81
Новосибирск (383)227-86-73
Омск (3812)21-46-40
Орел (4862)44-53-42
Оренбург (3532)37-68-04
Пенза (8412)22-31-16
Россия (495)268-04-70

Пермь (342)205-81-47
Ростов-на-Дону (863)308-18-15
Рязань (4912)46-61-64
Самара (846)206-03-16
Санкт-Петербург (812)309-46-40
Саратов (845)249-38-78
Севастополь (8692)22-31-93
Симферополь (3652)67-13-56
Соленск (4812)29-41-54
Сочи (862)225-72-31
Ставрополь (8652)20-65-13
Казахстан (772)734-952-31

Сургут (3462)77-98-35
Тверь (4822)63-31-35
Томск (3822)98-41-53
Тула (4872)74-02-29
Тюмень (3452)66-21-18
Ульяновск (8422)24-23-59
Уфа (347)229-48-12
Хабаровск (4212)92-98-04
Челябинск (351)202-03-61
Череповец (8202)49-02-64
Ярославль (4852)69-52-93

4. Manual feed

4.4 Profiling

4.4.7 Multi-purpose profile cutterheads



Profile cutterhead, aluminium tool body

Application:

For profiling, jointing and rebating.

Machine:

Spindle moulders and moulders.

Workpiece material:

Softwood and hardwood.

Technical information:

Profile cutterhead with aluminium tool body for standard and special profile knives up to 50 mm cutting width and maximum profile depth 15 mm. Constant diameter by using changeable profile knives. Knife thickness 4 mm.



D 108 mm - 148 mm

WM 500 1 04, WM 500 1 06

D	SB	BO	BO _{max}	Z	n	QAL	ID
mm	mm	mm	mm		min ⁻¹		
108	40	30	30	2	6000 - 10000	SP	025685 ●
128	40 - 50	30	40	2	6000 - 9000	SP	025815 ●
128	80	30	40	2	6000 - 8000	SP	025816 ●
148	40 - 50	30	50	2	5500 - 7000	SP	025691 ●

See section Knives and Spare Parts.

Table for diameters when using rebating and profile knives:

D-mm Tool body	D-mm with rebating knife	D-mm with profile knife
93	108	130
114	128	150

Spare knives:

Part-no.	BEZ	ABM	QAL	ID
		mm		
1	Rebate knife	40x32.8x4	SP	007104 ●
2	Limiter	38.4x32.8x4	ST	005586 ●

Spare parts:

Part-no.	BEZ	ABM	ID
		mm	
3	Clamping wedge	36x13.21x26	009756 ●
3	Clamping wedge	56x13.21x26	009757 ●
4	Allen screw with ISK 5	M10x12	006044 ●
	Allen key	SW 5	005446 ●

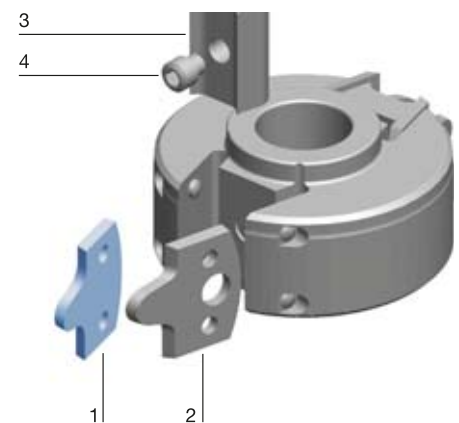

4. Manual feed

4.4 Profiling

4.4.7 Multi-purpose profile cutterheads



Profile cutterhead

Application:

For deep profiles with large profile depth, maximum 45 mm depth, with resharpenable profile knives and limitors. Easy to use, no setting gauge required.

Machine:

Spindle moulders and moulders.

Workpiece material:

Softwood and hardwood.

Technical information:

Cutting width up to 80.0 mm. Symmetrical tool body for right hand or left hand rotation as required.



MAN feed for symmetric profiles SB 60 - 80 mm

WM 520 1

D	SB	BO	BO _{max}	HD	PT _{max}	Z	n	ID
mm	mm	mm	mm	mm	mm		min ⁻¹	
180	60 - 80	30	40	80	45	2	4500 - 6000	026651 ●
180	60 - 80	40	40	80	45	2	4500 - 6000	026652 □

Sales unit without knives and limitors.

Note: State direction of rotation when ordering knives.

Spare knives:

Part-no.	BEZ	ABM	QAL	ID
		mm		
1	Blank Knife	60x60x6	HS	007278 ●
1	Blank Knife	80x60x6	HS	007279 ●
2	Limitor blank	58x59.2x6	SP	005594 ●
2	Limitor blank	78x59.2x6	SP	005595 ●

Spare parts:

Part-no.	BEZ	ABM	ID
		mm	
3	Clamping screw	M16x1.5x36 LH/RH	005958 ●
	Key	SW 17	005456 ●

HS-special profiles and SP-profile limitors

PG I	Set of profile knives	SB = 60 mm
PG II	Set of profile knives	SB = 60 mm
PG I	Set of profile knives	SB = 80 mm
PG II	Set of profile knives	SB = 80 mm
Set consists of:		2 HS-Profile knives
		2 SP-Limitors

Profile knives and limitors are produced to customer's profile.

Only use this cutterhead with original Leitz profile knives and limitors!

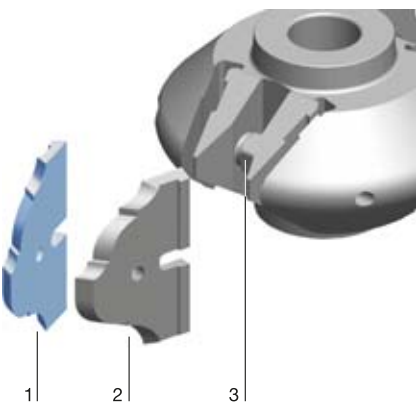
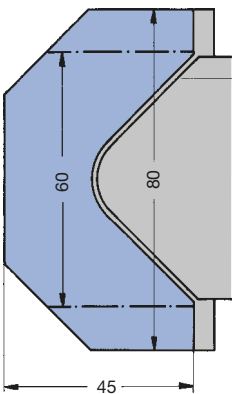

4. Manual feed

4.4 Profiling

4.4.7 Multi-purpose profile cutterheads



Profile cutterhead

Application:

For deep profiles with large profile depth, maximum 45 mm depth, with resharpenable profile knives and limitors. Easy to use, no setting gauge required.

Machine:

Spindle moulders and moulders.

Workpiece material:

Softwood and hardwood.

Technical information:

Cutting width up to 80.0 mm. Symmetrical tool body for right hand or left hand rotation as required.



MAN feed for symmetric closed profiles SB 60 - 80 mm

WM 540 1

D	SB	BO	BO _{max}	HD	PT _{max}	Z	n	ID
mm	mm	mm	mm	mm	mm		min ⁻¹	
180	60 - 80	30	40	80	45	2	4500 - 6000	026865 ●
180	60 - 80	40	40	80	45	2	4500 - 6000	026866 □

Sales unit without knives and limitors.

Note: State direction of rotation when ordering knives.

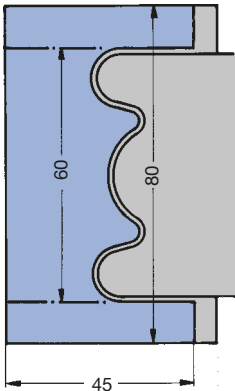

Spare knives:

Part-no.	BEZ	ABM	QAL	ID
		mm		
1	Blank Knife	60x60x6	HS	007276 ●
1	Blank Knife	80x60x6	HS	007277 ●
2	Limiter blank	58x59.2x6	SP	005600 ●
2	Limiter blank	78x59.2x6	SP	005601 ●

Spare parts:

Part-no.	BEZ	ABM	ID
		mm	
3	Clamping screw	M16x1.5x36 LH/RH	005958 ●
	Key	SW 17	005456 ●

HS-special profiles and SP-profile limitors

PG I	Set of profile knives	SB = 60 mm
PG II	Set of profile knives	SB = 60 mm
PG I	Set of profile knives	SB = 80 mm
PG II	Set of profile knives	SB = 80 mm
Set consists of:		2 HS-Profile knives
		2 SP-Limitors

Profile knives and limitors are produced to customer's profile.

Only use this cutterhead with original Leitz profile knives and limitors!

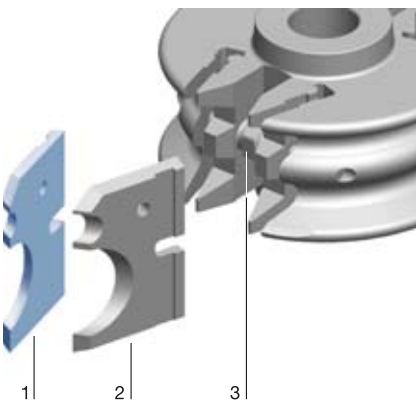

4. Manual feed

4.4 Profiling

4.4.7 Multi-purpose profile cutterheads



Profile cutterhead

Application:

For deep one-sided profiles, maximum 45 mm depth.

Machine:

Spindle moulders and moulders.

Workpiece material:

Softwood and hardwood.

Technical information:

Cutting width up to 50 mm. See illustration for usable profile area. Knife thickness 4.0 mm.



MAN feed, for one sided profiles with SB 50 mm

WM 530 1 01

D	TD	SB	BO	BO _{max}	Z	n	ID
mm	mm	mm	mm	mm		min ⁻¹	
200	148	50	30	40	2	4500 - 7000	029636 ●

Sales unit without knives and limitors.

Note: State direction of rotation when ordering knives.

Spare knives:

BEZ	BEM	ABM	QAL	ID
		mm		
Blank Knife	R/T	50.4x45x4	HS	007297 ●
Blank Knife	R/B	50.4x45x4	HS	007298 ●
Limiter blank	R/T	48.8x45x4	SP	005603 ●
Limiter blank	R/B	48.8x45x4	SP	005604 ●

Spare parts:

BEZ	ABM	ID
	mm	
Allen screw	M10x16	006046 ●
Allen key	SW 5	005446 ●
Double wedge	49.2x13.2x26	009927 ●

HS-special profiles and SP-profile limitors

Profile knives set inc. limitor	PG I	SB = 50 mm
Profile knives set inc. limitor	PG II	SB = 50 mm
Set consists of:	2 HS-Profile knives; 2 SP-Limitors	

Profile knives and limitors produced to customer's profile.

Only use this cutterhead with original Leitz profile knives and limitors!

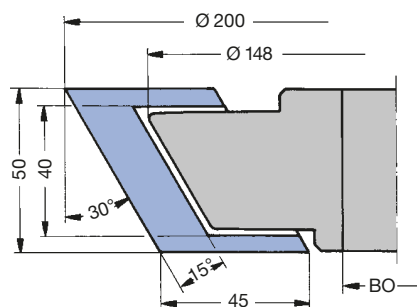

4. Manual feed

4.4 Profiling

4.4.7 Multi-purpose profile cutterheads



Profile cutterhead

Application:

For deep one-sided profiles with large profile depth, maximum 45 mm depth. Easy to use, no setting gauge required.

Machine:

Spindle moulders and moulders.

Workpiece material:

Softwood and hardwood.

Technical information:

Cutting width up to 80 mm. See illustration for usable profile area. Knife thickness 4.0 mm.



MAN feed, for one sided profiles with SB 60 - 80 mm

WM 530 1 02

D	SB	BO	BO _{max}	HD	PT _{max}	Z	n	ID
mm	mm	mm	mm	mm	mm		min ⁻¹	
180	60 - 80	30	40	80	45	2	4500 - 6000	026768 ●
180	60 - 80	40	40	80	45	2	4500 - 6000	026769 □

Sales unit without knives and limitors.

Note: State direction of rotation when ordering knives.

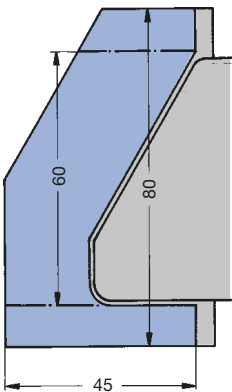

Spare knives:

Part-no.	BEZ	ABM	QAL	ID
		mm		
1	Blank Knife R/B	60x60x6	HS	007280 ●
1	Blank Knife R/B	80x60x6	HS	007281 ●
1	Blank Knife R/T	60x60x6	HS	007282 ●
1	Blank Knife R/T	80x60x6	HS	007283 ●
2	Limiter blank R/B (60)	58x59.2x6	SP	005596 ●
2	Limiter blank R/B (80)	78x59.2x6	SP	005597 ●
2	Limiter blank R/T (60)	58x59.2x6	SP	005598 ●
2	Limiter blank R/T (80)	78x59.2x6	SP	005599 ●

Spare parts:

Part-no.	BEZ	ABM	ID
		mm	
3	Clamping screw	M16x1.5x36 LH/RH	005958 ●
	Key	SW 17	005456 ●

HS-special profiles and SP-profile limitors

PG I	Set of profile knives	SB = 60 mm
PG II	Set of profile knives	SB = 60 mm
PG I	Set of profile knives	SB = 80 mm
PG II	Set of profile knives	SB = 80 mm
Set consists of:		2 HS-Profile knives
		2 SP-Limitors

Profile knives and limitors are produced to customer's profile.

Only use this cutterhead with original Leitz profile knives and limitors!

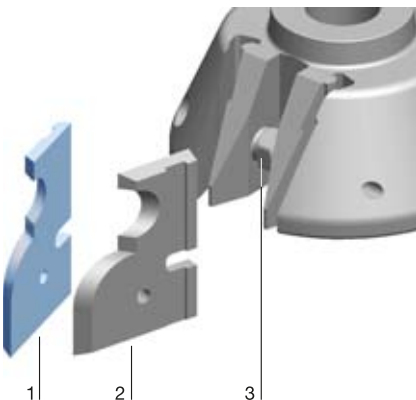

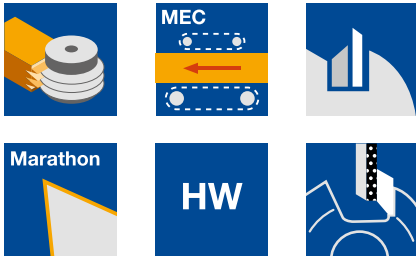

Minifinger joint cutterhead with replaceable knives

Application:

For self-locking longitudinal joints. See section introduction for additional information.

Machine:

Finger joint machines with and without cut-off saw, continuous machines.

Workpiece material:

Softwood and hardwood.

Technical information:

Steel tool body with block knives. Individually replaceable knives if damaged. Always resharpen sets of tools to the same diameter. Marathon coating allows up to 4 times longer tool life compared to HS version. Resharpener area 10 mm for MC or 6 mm for HW.

ZL 10/10 and 10/11 mm, MC

WM 620 2 06

D mm	SB mm	BO mm	ND mm	Z	TG	ZA PCS	n_{max} min ⁻¹	ID ZL	ID ZL
160	31.4	50	30.4	2/2	3.8	8	8000	10/10	10/11
250	31.4	50	30.4	3/3	3.8	8	4500	135900	135902
								135901	135903

ZL 10/10 and 10/11 mm, HW

WM 620 2

D mm	SB mm	BO mm	ND mm	Z	TG	ZA PCS	n_{max} min ⁻¹	ID ZL	ID ZL
160	31.4	50	30.4	2/2	3.8	8	8000	10/10	10/11
250	31.4	50	30.4	3/3	3.8	8	4500	022730	022731
								022732	022733

ZL 15/15 and 15/16.5 mm, MC

WM 620 2 06

D mm	SB mm	BO mm	ND mm	Z	TG	ZA PCS	n_{max} min ⁻¹	ID ZL	ID ZL
170	31.4	50	30.4	2/2	3.8	8	8000	15/15	15/16.5
260	31.4	50	30.4	3/3	3.8	8	4500	135904	135906
								135905	135907

ZL 20/20 and 20/22 mm, MC

WM 620 2 06

D mm	SB mm	BO mm	ND mm	Z	TG	ZA PCS	n_{max} min ⁻¹	ID ZL	ID ZL
180	39.2	50	37.2	2/2	6.2	6	8000	20/20	20/22
260	39.2	50	37.2	3/3	6.2	6	4500	135908	135910
								135909	135911

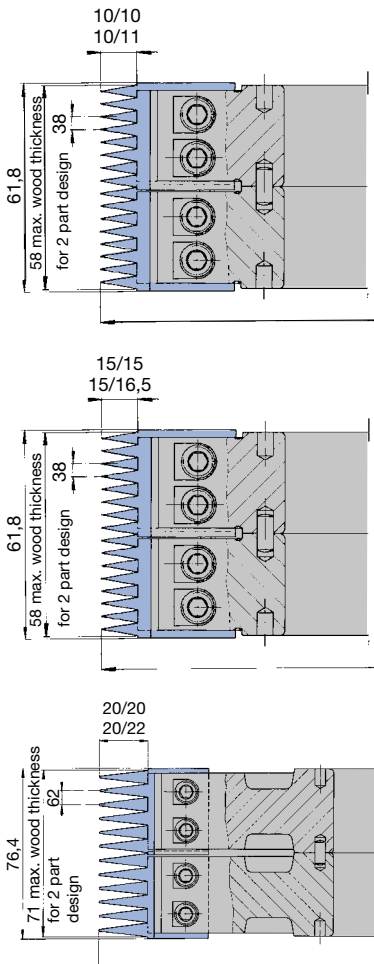

Архангельск (8182)63-90-72
Астана (7172)727-132
Астрахань (8512)99-46-04
Барнаул (3852)73-04-60
Белгород (4722)40-23-64
Брянск (4832)59-03-52
Владивосток (423)249-28-31
Волгоград (844)278-03-48
Вологда (8172)26-41-59
Воронеж (473)204-51-73
Екатеринбург (343)384-55-89
Иваново (4932)77-34-06

Ижевск (3412)26-03-58
Иркутск (395)279-98-46
Казань (843)206-01-48
Калининград (4012)72-03-81
Калуга (4842)92-23-67
Кемерово (3842)65-04-62
Киров (8332)68-02-04
Краснодар (861)203-40-90
Красноярск (391)204-63-61
Курск (4712)77-13-04
Липецк (4742)52-20-81
Киргизия (996)312-96-26-47

Магнитогорск (3519)55-03-13
Москва (495)268-04-70
Мурманск (8152)59-64-93
Набережные Челны (8552)20-53-41
Нижний Новгород (831)429-08-12
Новокузнецк (3843)20-46-81
Новосибирск (383)227-86-73
Омск (3812)21-46-40
Орел (4862)44-53-42
Оренбург (3532)37-68-04
Пенза (8412)22-31-16
Россия (495)268-04-70

Пермь (342)205-81-47
Ростов-на-Дону (863)308-18-15
Рязань (4912)46-61-64
Самара (846)206-03-16
Санкт-Петербург (812)309-46-40
Саратов (845)249-38-78
Севастополь (8692)22-31-93
Симферополь (3652)67-13-56
Смоленск (4812)29-41-54
Сочи (862)225-72-31
Ставрополь (8652)20-65-13
Казахстан (772)734-952-31

Сургут (3462)77-98-35
Тверь (4822)63-31-35
Томск (3822)98-41-53
Тула (4872)74-02-29
Тюмень (3452)66-21-18
Ульяновск (8422)24-23-59
Уфа (347)229-48-12
Хабаровск (4212)92-98-04
Челябинск (351)202-03-61
Череповец (8202)49-02-64
Ярославль (4852)69-52-93