



Profile cutter flexTrim

Application:

For multi-profile cutting with radii and bevelling of edges. Combination of two profiles for automatic profile resetting in the workpiece gap.

Machine:

Homag edgbanding machines for cutting units types FK11, FK20, FK21, FF12, FF32, PF21 with flexTrim cutting head.

Workpiece material:

Plastic, softwood, hardwood and veneer edgbander.

Technical information:

2 part DP composite tool for setwise application. DFC design for efficient chip collection. Maximum processing quality through high running accuracy and quiet running. $D_0 = \text{constant reference diameter}$, $\text{RPM } n_{\text{max}} = 18,000 \text{ min}^{-1}$.

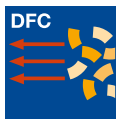
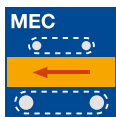
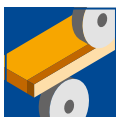

Multi-profile cutterset flexTrim - Diamaster PRO

SF 542 2 15

Machine	D	D ₀	NH	BO	Z	QAL	R	FAW	ID	ID
	mm	mm	mm	mm			mm	°	LH	RH
Homag	78	70	19.5	HSK 25 R	4	DP	1.5/1.0		194300 ●	194301 ●
Homag	78	70	19.5	HSK 25 R	4	DP	2.0/1.0		194302 ●	194303 ●
Homag	78	70	19.5	HSK 25 R	4	DP	2.0/1.5		194304 ●	194305 ●
Homag	78	70	19.5	HSK 25 R	4	DP	3.0/2.0		194306 ●	194307 ●
Homag	78	70	19.5	HSK 25 R	4	DP	2.0	20°	194308 ●	194309 ●
Homag	78	70	19.5	HSK 25 R	4	DP	2.0	45°	194310 ●	194311 ●

Tool 1 fix + tool 2 flexible

All tools and further profile variants available in various dimensions from blank at short notice. Further combinations possible on request.

Spare parts:

Part-no.	Tool no.	BEZ	ABM	ID
			mm	
3	2	O-Ring	40x1.78 NBR70	118300 ●

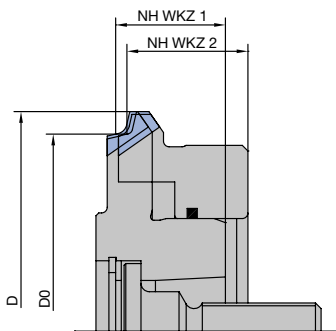

1 = Tool 1
2 = Tool 2
3 = O-Ring

Архангельск (8182)63-90-72
Астана (7172)727-132
Астрахань (8512)99-46-04
Барнаул (3852)73-04-60
Белгород (4722)40-23-64
Брянск (4832)59-03-52
Владивосток (423)249-28-31
Волгоград (844)278-03-48
Вологда (8172)26-41-59
Воронеж (473)204-51-73
Екатеринбург (343)384-55-89
Иваново (4932)77-34-06

Ижевск (3412)26-03-58
Иркутск (395)279-98-46
Казань (843)206-01-48
Калининград (4012)72-03-81
Калуга (4842)92-23-67
Кемерово (3842)65-04-62
Киров (8332)68-02-04
Краснодар (861)203-40-90
Красноярск (391)204-63-61
Курск (4712)77-13-04
Липецк (4742)52-20-81
Киргизия (996)312-96-26-47

Магнитогорск (3519)55-03-13
Москва (495)268-04-70
Мурманск (8152)59-64-93
Набережные Челны (8552)20-53-41
Нижний Новгород (831)429-08-12
Новокузнецк (3843)20-46-81
Новосибирск (383)227-86-73
Омск (3812)21-46-40
Орел (4862)44-53-42
Оренбург (3532)37-68-04
Пенза (8412)22-31-16
Россия (495)268-04-70

Пермь (342)205-81-47
Ростов-на-Дону (863)308-18-15
Рязань (4912)46-61-64
Самара (846)206-03-16
Санкт-Петербург (812)309-46-40
Саратов (845)249-38-78
Севастополь (8692)22-31-93
Симферополь (3652)67-13-56
Смоленск (4812)29-41-54
Сочи (862)225-72-31
Ставрополь (8652)20-65-13
Казахстан (772)734-952-31

Сургут (3462)77-98-35
Тверь (4822)63-31-35
Томск (3822)98-41-53
Тула (4872)74-02-29
Тульня (3452)66-21-18
Ульяновск (8422)24-23-59
Уфа (347)229-48-12
Хабаровск (4212)92-98-04
Челябинск (351)202-03-61
Череповец (8202)49-02-64
Ярославль (4852)69-52-93

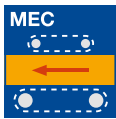
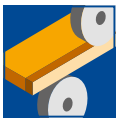

Profile cutter flexTrim3

Application:

For multi-profile cutting with radii on edges. Combination of three profiles for automatic profile resetting.

Machine:

Homag edgebanding machines for cutting units type FF32 with flexTrim cutting head.

Workpiece material:

Plastic, softwood, hardwood and veneer edgebander.

Technical information:

DP composite tool for setwise application. Maximum processing quality through high running accuracy and quiet running.

D_0 = constant reference diameter, RPM $n_{max} = 12.000 \text{ min}^{-1}$.

Multi-profile cutterset flexTrim3 - Diamaster PRO

SF 541 2 17

Machine	D	D_0	NH	BO	Z	QAL	R	ID	ID
	mm	mm	mm	mm			mm	LH	RH
Homag	78	70	28	HSK 25 R	4	DP	2/1.5/1	194500 ●	194501 ●
Homag	78	70	28	HSK 25 R	4	DP	2/1.3/1	194502 ●	194503 ●

Further profile variants and combinations possible on request.

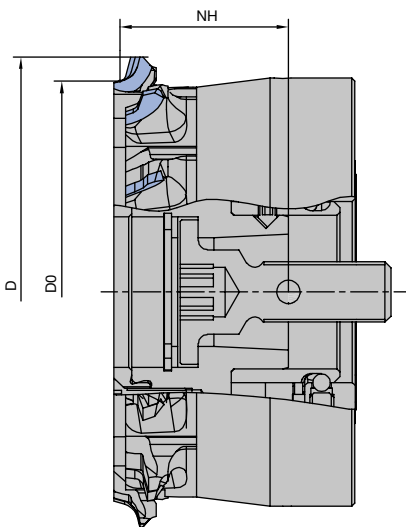

Diamaster PRO - single tools

WF 501 2 17

Tool no.	D	D_0	BO	Z	QAL	R	ID	ID
	mm	mm	mm			mm	LH	RH
1	78	70	30	4	DP	2	194403 ●	194411 ●
2	78	70	45	4	DP	1.3	194417 ●	194425 ●
2	78	70	45	4	DP	1.5	194418 ●	194426 ●
3	78	70	40	4	DP	1	194432 ●	194440 ●

It is recommended to change single tools only in the course of a service by Homag or by the Leitz tool service. Single tools are delivered with appropriate compression springs and screws.

Spare parts:

Part-no.	BEZ	ABM	ID
		mm	
4	Multi-profile cutter aggregate	D71x37.2xHSK25R	194350 ●



2. Panel processing

2.1 Edge processing 2.1.7 Edge finishing tools

Profile cutter Quattro^{Form}



Application:

For multi-profile cutting with radii and bevelling of edges.

Machine:

Holz-Her model Lumina and Accura 2015 and newer models. Application on Revolver cutting unit Quattro Form (FF 701 Multi).

Workpiece material:

Plastic, softwood, hardwood and veneer edgebander.

Technical information:

DP composite tool with 4 profiles and mounting screw. Profiles automatically adjustable by the machine control. Patented system.

D_0 = constant reference diameter, RPM $n = 18,000 \text{ min}^{-1}$.

Multi-profile cutter Quattro^{Form} - Diamaster PRO

SF 540 2 10

Machine	D	D_0	BO	Z	R	FAW	ID	ID
	mm	mm	mm		mm	°	LH	RH
Holz-Her FF 701 Multi	70	61	16	3	2/1.3/2	45°	194001 ●	194000 ●
Holz-Her FF 701 Multi	70	61	16	3	3/1.3/2	45°	194003 ●	194002 ●
Holz-Her FF 701 Multi	70	61	16	3	3/1.3/2	10°	194005 ●	194004 ●
Holz-Her FF 701 Multi	70	61	16	3	2/1.3/1.3	45°	194007 ●	194006 ●
Holz-Her FF 701 Multi	70	61	16	3	2/1.5/1	45°	194009 ●	194008 ●
Holz-Her FF 701 Multi	70	61	16	3	0.8/1/1.3	45°	194011 ●	194010 ●

All tools and further profile variants are available in various dimensions from blanks at short notice. Profile radius maximum 3 mm.

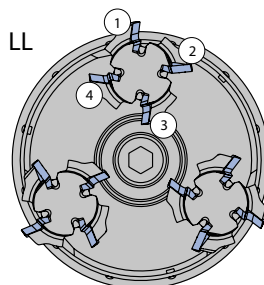
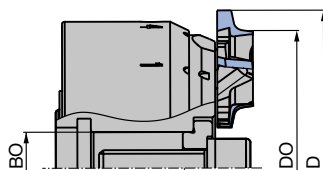
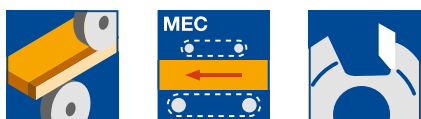

①	②	③	④	Leitz-Id.	Holzher
R2	R1.3	R2	F45°	194001	5043200
R3	R1.3	R2	F45°	194003	5044921
R3	R1.3	R2	F10°	194005	5046609
R2	R1.3	R3	F45°	194007	5048079
R2	R1.5	R1	F45°	194009	
R0.8	R1	R1.3	F45°	194011	5050821

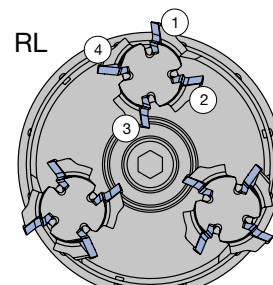

①	②	③	④	Leitz-Id.	Holzher
R2	R1.3	R2	F45°	194000	5043199
R3	R1.3	R2	F45°	194002	5044920
R3	R1.3	R2	F10°	194004	5046608
R2	R1.3	R3	F45°	194006	5048078
R2	R1.5	R1	F45°	194008	
R0.8	R1	R1.3	F45°	194010	5050822

Архангельск (8182)63-90-72
Астана (7172)727-132
Астрахань (8512)99-46-04
Барнаул (3852)73-04-60
Белгород (4722)40-23-64
Брянск (4832)59-03-52
Владивосток (423)249-28-31
Волгоград (844)278-03-48
Вологда (8172)26-41-59
Воронеж (473)204-51-73
Екатеринбург (343)384-55-89
Иваново (4932)77-34-06

Ижевск (3412)26-03-58
Иркутск (395)279-98-46
Казань (843)206-01-48
Калининград (4012)72-03-81
Калуга (4842)92-23-67
Кемерово (3842)65-04-62
Киров (8332)68-02-04
Краснодар (861)203-40-90
Красноярск (391)204-63-61
Курск (4712)77-13-04
Липецк (4742)52-20-81
Киргизия (996)312-96-26-47

Магнитогорск (3519)55-03-13
Москва (495)268-04-70
Мурманск (8152)59-64-93
Набережные Челны (8552)20-53-41
Нижний Новгород (831)429-08-12
Новокузнецк (3843)20-46-81
Новосибирск (383)227-86-73
Омск (3812)21-46-40
Орел (4862)44-53-42
Оренбург (3532)37-68-04
Пенза (8412)22-31-16
Россия (495)268-04-70

Пермь (342)205-81-47
Ростов-на-Дону (863)308-18-15
Рязань (4912)46-61-64
Самара (846)206-03-16
Санкт-Петербург (812)309-46-40
Саратов (845)249-38-78
Севастополь (8692)22-31-93
Симферополь (3652)67-13-56
Смоленск (4812)29-41-54
Сочи (862)225-72-31
Ставрополь (8652)20-65-13
Казахстан (772)734-952-31

Сургут (3462)77-98-35
Тверь (4822)63-31-35
Томск (3822)98-41-53
Тула (4872)74-02-29
Тюмень (3452)66-21-18
Ульяновск (8422)24-23-59
Уфа (347)229-48-12
Хабаровск (4212)92-98-04
Челябинск (351)202-03-61
Череповец (8202)49-02-64
Ярославль (4852)69-52-93

<https://leitz.nt-rt.ru/> || lzt@nt-rt.ru