



Turnblade jointing / rebating cutterhead

Application:

Optimized for rebating, jointing and grooving with and against feed.

Machine:

Stationary routers with/without CNC control, CNC machining centres.

Workpiece material:

Softwood and hardwood, compound materials of solid wood and wood derived materials, uncoated, plastic coated, veneered etc., laminated veneer lumber (plywood, multiplex plywood etc.).

Technical information:

Cutterhead with turnblades and alternate shear angle, righthand rotation. Knife seatings for grooving and edging knives for seal groove and edge roundings. Tool body in lightweight aluminium for a better dynamic situation.

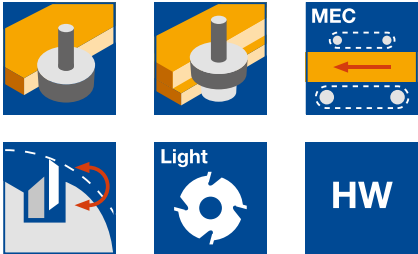

HW, Z 2 / V 2, with seatings for edging knives

SL 499 2, SW 530 2

Tool Type	QAL	Z	V	ID
Cutterhead with spacers	HW	2	2	126040 ●
Cutterhead mounted on arbor	HW	2	2	426081 □

RPM: $n_{max} = 14300 \text{ min}^{-1}$

Spare knives:

BEZ	ABM	R	FAW	ID
	mm	mm	°	
Turnblade knife	40x8x1.5			005074 ●
Turnblade spur VS2	19x19x2			005115 ●
Edging knife	KM 11/0		45°	008268 ●
Edging knife	KM 12/3	2		008307 ●
Turnblade grooving knife NA5	35.2x15x5			008318 ●
Turnblade grooving knife NA4	35.2x15x4			008317 ●

Spare parts:

BEZ	BEM	ABM	ID
		mm	
Set of spacers	for groove/edge knives	12.9x20x6.1	028565 ●
Spacer	for groove/edge knives	13/6.1x3	028185 ●
Spacer	for groove/edge knives	13/6.1x1	028037 ●
Countersink screw, Torx® 20	for groove/edge knives	M6x40	006090 ●
Countersink screw, Torx® 20	for groove/edge knives	M6x14	006085 ●
Clamping wedge		38x18.75x8.27	009675 ●
Countersink screw, Torx® 20	for spurs	M5x8.5	007808 ●
Clamping screw w. disc, Torx® 25		M6x18.5	007442 ●
Torx® 25			
Cylindrical screw with ISK		M5x80	007097 ●
Torx® key		Torx® 20	117503 ●
Torx® key		Torx® 25	117504 ●
Allen key		SW 4, L 100	005451 ●

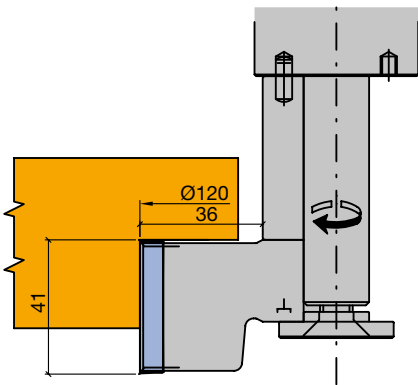

Order example:

Tool set ID **426081** mounted on arbor ID **042847**, HSK-F 63 (A = 80 mm).
When ordering choose arbors with d = 20 mm and clamping length 70 mm.

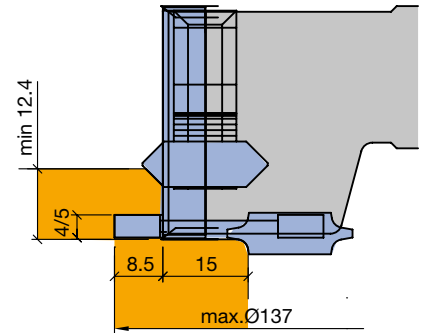
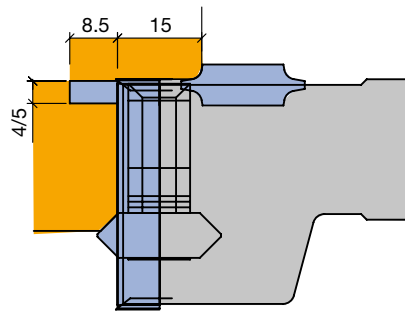
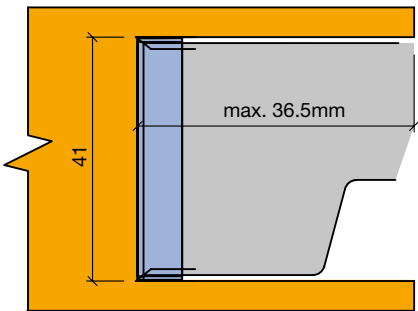

Архангельск (8182)63-90-72
Астана (7172)727-132
Астрахань (8512)99-46-04
Барнаул (3852)73-04-60
Белгород (4722)40-23-64
Брянск (4832)59-03-52
Владивосток (423)249-28-31
Волгоград (844)278-03-48
Вологда (8172)26-41-59
Воронеж (473)204-51-73
Екатеринбург (343)384-55-89
Иваново (4932)77-34-06

Ижевск (3412)26-03-58
Иркутск (395)279-98-46
Казань (843)206-01-48
Калининград (4012)72-03-81
Калуга (4842)92-23-67
Кемерово (3842)65-04-62
Киров (8332)68-02-04
Краснодар (861)203-40-90
Красноярск (391)204-63-61
Курск (4712)77-13-04
Липецк (4742)52-20-81
Киргизия (996)312-96-26-47

Магнитогорск (3519)55-03-13
Москва (495)268-04-70
Мурманск (8152)59-64-93
Набережные Челны (8552)20-53-41
Нижний Новгород (831)429-08-12
Новокузнецк (3843)20-46-81
Новосибирск (383)227-86-73
Омск (3812)21-46-40
Орел (4862)44-53-42
Оренбург (3532)37-68-04
Пенза (8412)22-31-16
Россия (495)268-04-70

Пермь (342)205-81-47
Ростов-на-Дону (863)308-18-15
Рязань (4912)46-61-64
Самара (846)206-03-16
Санкт-Петербург (812)309-46-40
Саратов (845)249-38-78
Севастополь (8692)22-31-93
Симферополь (3652)67-13-56
Смоленск (4812)29-41-54
Сочи (862)225-72-31
Ставрополь (8652)20-65-13
Казахстан (772)734-952-31

Сургут (3462)77-98-35
Тверь (4822)63-31-35
Томск (3822)98-41-53
Тула (4872)74-02-29
Тюмень (3452)66-21-18
Ульяновск (8422)24-23-59
Уфа (347)229-48-12
Хабаровск (4212)92-98-04
Челябинск (351)202-03-61
Череповец (8202)49-02-64
Ярославль (4852)69-52-93

5. Routing

5.2 Jointing, rebating and bevelling

5.2.1 Jointing and rebating tools



Jointing cutterhead set with edging knives

Application:

For jointing and rounding or bevelling narrow edges with a constant tool diameter.

Machine:

Stationary routers with/without CNC control, machining centres.

Workpiece material:

Softwood and hardwood, compound materials of solid wood and wood derived materials, uncoated, plastic coated, veneered etc., laminated veneer lumber (plywood, multiplex plywood etc.).

Technical information:

Tungsten carbide turnblade knives Z 2 with shear angles. Narrow edge profiling with edging knives mounted on both sides of tool. Smooth running due to closed, round tool body.

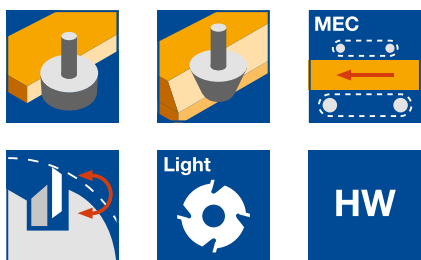

HW, Z 2, with seatings for edging knives

SL 299 2, SW 510 2

Tool Type	ABM mm	QAL	Z	ID
Tool set without arbor, with spacer	85x50x20.1-part	HW	2	125038 ●
Tool set mounted on arbor	1-part.HD40	HW	2	426000 □
Tool set without arbor, with spacer	110x100x28x30	HW	2	411179 ●
Tool set mounted on arbor	1-part	HW	2	426085 □

Examples

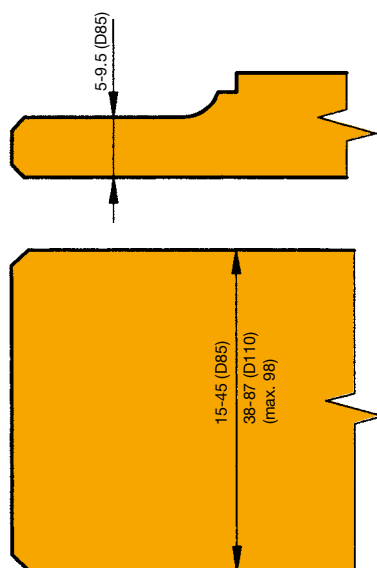
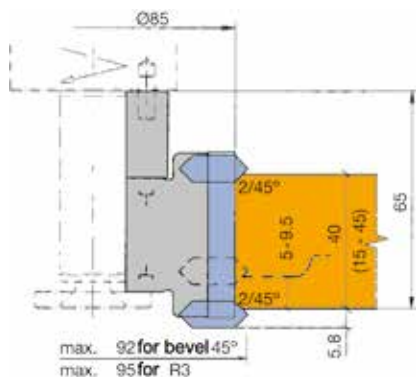

RPM: D 85 mm: $n_{\max} = 17900 \text{ min}^{-1}$

D 110 mm: $n_{\max} = 15600 \text{ min}^{-1}$

Unless stated otherwise, tools are right hand rotation.

Cutter arbor see section Clamping Systems.

Spare knives:

BEZ	ABM mm	QAL	R mm	FAW °	VE PCS	ID
Turnblade knife	50x8x1.5	HW-05			10	005402 ●
Turnblade knife	100x8x1.5	HW-05				005405 ●
Edging knife	KM 12/4	HW-F	1.5			008272 ●
Edging knife	KM 12/3	HW-F	2			008307 ●
Edging knife	KM 12/0	HW-F	3			008270 ●
Edging knife	KM 15/0	HW-F	3			008275 ●
Edging knife	KM 12/1	HW-F	3			008271 ●
Edging knife	KM 11/0	HW-F		45°		008268 ●

Spare parts:

BEZ	ABM mm	ID
Clamping wedge	48x18.75x8.27	009677 ●
Clamping wedge	98x18.75x8.27	009681 ●
Clamping screw w. disc, Torx® 25	M6x18.5	007442 ●
Countersink screw, Torx® 20	M6x35	007098 ●
Torx® key	Torx® 20	117503 ●
Torx® key	Torx® 25	117504 ●
Magnetic setting gauge	0.3/0.8	005376 ●

Order example:

Tool set ID **426000** mounted on arbor ID **041125**, shank 25x60 mm.

When ordering, choose arbors with $d = 20 \text{ mm}$ and clamping length 55 mm.

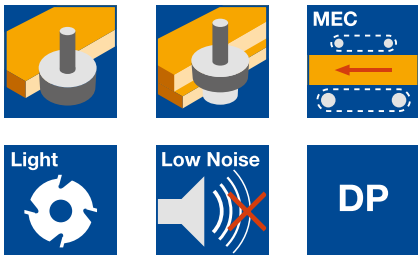

WhisperCut jointing and rebating cutterhead

Application:

For tear-free and low noise jointing of the cutting surface.

Machine:

Stationary routers with/without CNC control, machining centres.

Workpiece material:

Chipboard and fibre materials (MDF, HDF etc.), uncoated, plastic coated, paper coated, fibre reinforced plastics (GFRP, CFRP etc.).

Technical information:

Cutterhead with DP knives with alternate shear angle for tear-free jointing edges and cutting surfaces. Noise reduced design with noise reduction of up to 5 dB(A) and highly efficient chip collection (>95%) by DFC. Significant weight reduction through lightweight aluminium tool body. Several times applicable through exchangeable knives. 0.6 mm resharpening area.

Diamaster WhisperCut jointing cutterhead

WM 230 2 01, WP 299 2

Tool Type	ABM mm	QAL	Z	ID
Cutterhead	70x33x20	DP	2/2/2	192273 ●
Cutterhead mounted on arbor	1-part/HD28	DP	2/2/2	192274 □

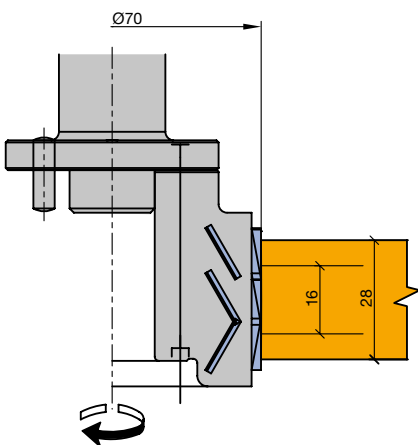

Diamaster WhisperCut jointing cutterhead

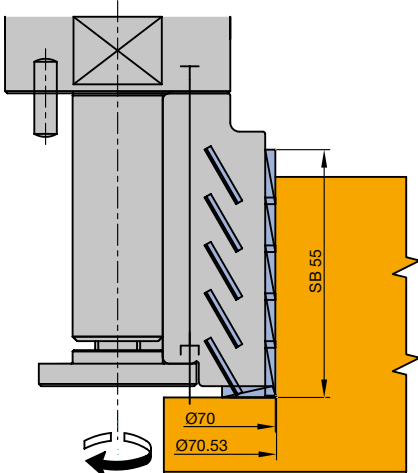

Diamaster WhisperCut rebating cutterhead

Application:

For tear-free and low noise rebating of the cutting surface.

Technical information:

Cutterhead with DP knives. For Tear-free rebates due to optimised knife arrangement with shear angle and separate bottom tip (spurs). Not suitable for jointing. Several times applicable through exchangeable knives.

Noise reduced design with noise reduction of up to 5 dB(A) and highly efficient chip collection (>95%) by DFC. Significant weight reduction through lightweight aluminium tool body.

Diamaster WhisperCut rebating cutterhead

WM 430 2 01, WP 499 2

Tool Type	ABM mm	QAL	Z	ID
Cutterhead	70.53x55x20	DP	3x5	192275 ●
Cutterhead mounted on arbor	D70.53/SB55	DP	3x5	192276 □

Unless stated otherwise, tools are right hand rotation.

Cutter arbor see section Clamping Systems.

Order example:

Tool set ID **192274** mounted on arbor

ID **041126**, shank 25x60 mm.

In case of order select arbors with $d = 20$ mm and biggest clamping length of the respective type.

Архангельск (8182)63-90-72
Астана (7172)727-132
Астрахань (8512)99-46-04
Барнаул (3852)73-04-60
Белгород (4722)40-23-64
Брянск (4832)59-03-52
Владивосток (423)249-28-31
Волгоград (844)278-03-48
Волгодда (8172)26-41-59
Воронеж (473)204-51-73
Екатеринбург (343)384-55-89
Иваново (4932)77-34-06

Ижевск (3412)26-03-58
Иркутск (395)279-98-46
Казань (843)206-01-48
Калининград (4012)72-03-81
Калуга (4842)92-23-67
Кемерово (3842)65-04-62
Киров (8332)68-02-04
Краснодар (861)203-40-90
Красноярск (391)204-63-61
Курск (4712)77-13-04
Липецк (4742)52-20-81
Киргизия (996)312-96-26-47

Магнитогорск (3519)55-03-13
Москва (495)268-04-70
Мурманск (8152)59-64-93
Набережные Челны (8552)20-53-41
Нижегород (831)429-08-12
Новокузнецк (3843)20-46-81
Новосибирск (383)227-86-73
Омск (3812)21-46-40
Орел (4862)44-53-42
Оренбург (3532)37-68-04
Пенза (8412)22-31-16
Россия (495)268-04-70

Пермь (342)205-81-47
Ростов-на-Дону (863)308-18-15
Рязань (4912)46-61-64
Самара (846)206-03-16
Санкт-Петербург (812)309-46-40
Саратов (845)249-38-78
Севастополь (8692)22-31-93
Симферополь (3652)67-13-56
Смоленск (4812)29-41-54
Сочи (862)225-72-31
Ставрополь (8652)20-65-13
Казахстан (772)734-952-31

Сургут (3462)77-98-35
Тверь (4822)63-31-35
Томск (3822)98-41-53
Тула (4872)74-02-29
Тюмень (3452)66-21-18
Ульяновск (8422)24-23-59
Уфа (347)229-48-12
Хабаровск (4212)92-98-04
Челябинск (351)202-03-61
Череповец (8202)49-02-64
Ярославль (4852)69-52-93