



Turnblade jointing / rebating cutterhead

Application:

Optimized for rebating, jointing and grooving with and against feed.

Machine:

Stationary routers with/without CNC control, CNC machining centres.

Workpiece material:

Softwood and hardwood, compound materials of solid wood and wood derived materials, uncoated, plastic coated, veneered etc., laminated veneer lumber (plywood, multiplex plywood etc.).

Technical information:

Cutterhead with turnblades and alternate shear angle, righthand rotation. Knife seatings for grooving and edging knives for seal groove and edge roundings. Tool body in lightweight aluminium for a better dynamic situation.

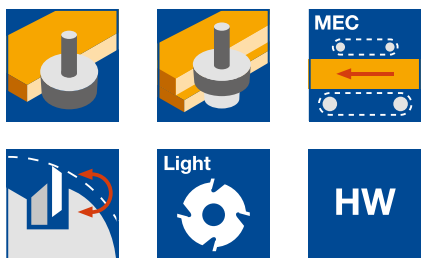

HW, Z 2 / V 2, with seatings for edging knives

SL 499 2, SW 530 2

Tool Type	QAL	Z	V	ID
Cutterhead with spacers	HW	2	2	126040 ●
Cutterhead mounted on arbor	HW	2	2	426081 □

RPM: n_{max} = 14300 min⁻¹

Spare knives:

BEZ	ABM	R	FAW	ID
	mm	mm	°	
Turnblade knife	40x8x1.5			005074 ●
Turnblade spur VS2	19x19x2			005115 ●
Edging knife	KM 11/0		45°	008268 ●
Edging knife	KM 12/3	2		008307 ●
Turnblade grooving knife NA5	35.2x15x5			008318 ●
Turnblade grooving knife NA4	35.2x15x4			008317 ●

Spare parts:

BEZ	BEM	ABM	ID
		mm	
Set of spacers	for groove/edge knives	12.9x20x6.1	028565 ●
Spacer	for groove/edge knives	13/6.1x3	028185 ●
Spacer	for groove/edge knives	13/6.1x1	028037 ●
Countersink screw, Torx® 20	for groove/edge knives	M6x40	006090 ●
Countersink screw, Torx® 20	for groove/edge knives	M6x14	006085 ●
Clamping wedge		38x18.75x8.27	009675 ●
Countersink screw, Torx® 20	for spurs	M5x8.5	007808 ●
Clamping screw w. disc, Torx® 25	Torx® 25	M6x18.5	007442 ●
Torx® 25			
Cylindrical screw with ISK		M5x80	007097 ●
Torx® key		Torx® 20	117503 ●
Torx® key		Torx® 25	117504 ●
Allen key		SW 4, L 100	005451 ●

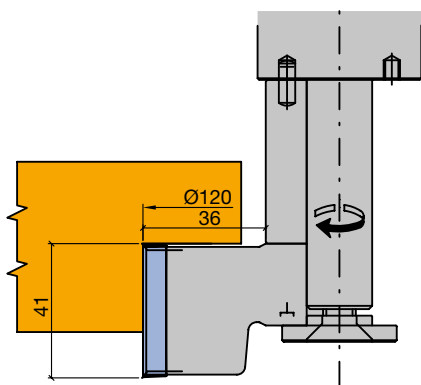

Order example:

Tool set ID **426081** mounted on arbor ID **042847**, HSK-F 63 (A = 80 mm). When ordering choose arbors with d = 20 mm and clamping length 70 mm.

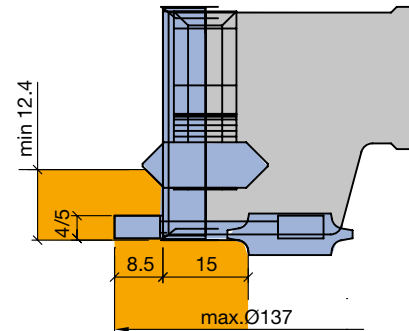
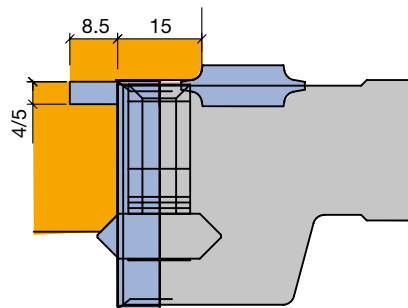
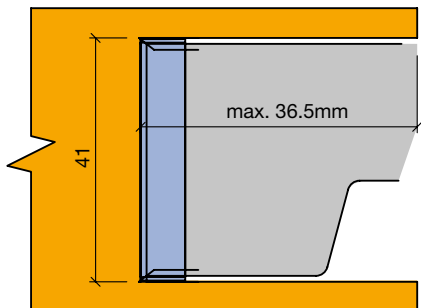

Архангельск (8182)63-90-72
 Астана (7172)727-132
 Астрахань (8512)99-46-04
 Барнаул (3852)73-04-60
 Белгород (4722)40-23-64
 Брянск (4832)59-03-52
 Владивосток (423)249-28-31
 Волгоград (844)278-03-48
 Вологда (8172)26-41-59
 Воронеж (473)204-51-73
 Екатеринбург (343)384-55-89
 Иваново (4932)77-34-06

Ижевск (3412)26-03-58
 Иркутск (395)279-98-46
 Казань (843)206-01-48
 Калининград (4012)72-03-81
 Калуга (4842)92-23-67
 Кемерово (3842)65-04-62
 Киров (8332)68-02-04
 Краснодар (861)203-40-90
 Красноярск (391)204-63-61
 Курск (4712)77-13-04
 Липецк (4742)52-20-81
 Киргизия (996)312-96-26-47

Магнитогорск (3519)55-03-13
 Москва (495)268-04-70
 Мурманск (8152)59-64-93
 Набережные Челны (8552)20-53-41
 Нижний Новгород (831)429-08-12
 Новокузнецк (3843)20-46-81
 Новосибирск (383)227-86-73
 Омск (3812)21-46-40
 Орел (4862)44-53-42
 Оренбург (3532)37-68-04
 Пенза (8412)22-31-16
 Россия (495)268-04-70

Пермь (342)205-81-47
 Ростов-на-Дону (863)308-18-15
 Рязань (4912)46-61-64
 Самара (846)206-03-16
 Санкт-Петербург (812)309-46-40
 Саратов (845)249-38-78
 Севастополь (8692)22-31-93
 Симферополь (3652)67-13-56
 Смоленск (4812)29-41-54
 Сочи (862)225-72-31
 Ставрополь (8652)20-65-13
 Казахстан (772)734-952-31

Сургут (3462)77-98-35
 Тверь (4822)63-31-35
 Томск (3822)98-41-53
 Тула (4872)74-02-29
 Тюмень (3452)66-21-18
 Ульяновск (8422)24-23-59
 Уфа (347)229-48-12
 Хабаровск (4212)92-98-04
 Челябинск (351)202-03-61
 Череповец (8202)49-02-64
 Ярославль (4852)69-52-93

5. Routing

5.2 Jointing, rebating and bevelling

5.2.1 Jointing and rebating tools



Jointing cutterhead set with edging knives

Application:

For jointing and rounding or bevelling narrow edges with a constant tool diameter.

Machine:

Stationary routers with/without CNC control, machining centres.

Workpiece material:

Softwood and hardwood, compound materials of solid wood and wood derived materials, uncoated, plastic coated, veneered etc., laminated veneer lumber (plywood, multiplex plywood etc.).

Technical information:

Tungsten carbide turnblade knives Z 2 with shear angles. Narrow edge profiling with edging knives mounted on both sides of tool. Smooth running due to closed, round tool body.

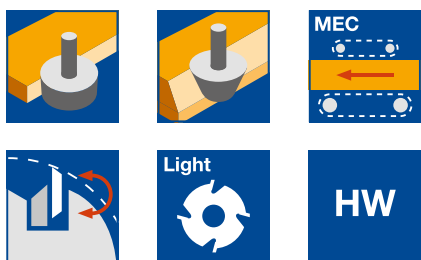

HW, Z 2, with seatings for edging knives

SL 299 2, SW 510 2

Tool Type	ABM mm	QAL	Z	ID
Tool set without arbor, with spacer	85x50x20.1-part	HW	2	125038 ●
Tool set mounted on arbor	1-part.HD40	HW	2	426000 □
Tool set without arbor, with spacer	110x100x28x30	HW	2	411179 ●
Tool set mounted on arbor	1-part	HW	2	426085 □

Examples

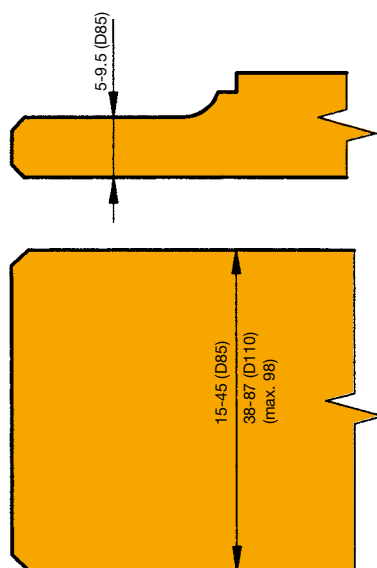
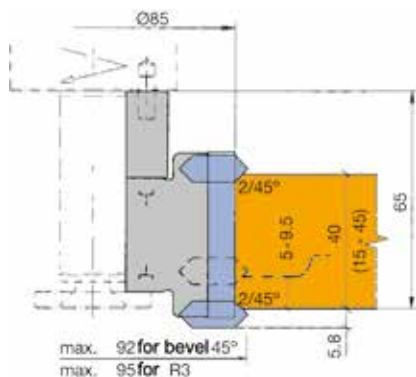

RPM: D 85 mm: $n_{max} = 17900 \text{ min}^{-1}$

D 110 mm: $n_{max} = 15600 \text{ min}^{-1}$

Unless stated otherwise, tools are right hand rotation.

Cutter arbor see section Clamping Systems.

Spare knives:

BEZ	ABM mm	QAL	R mm	FAW °	VE PCS	ID
Turnblade knife	50x8x1.5	HW-05			10	005402 ●
Turnblade knife	100x8x1.5	HW-05				005405 ●
Edging knife	KM 12/4	HW-F	1.5			008272 ●
Edging knife	KM 12/3	HW-F	2			008307 ●
Edging knife	KM 12/0	HW-F	3			008270 ●
Edging knife	KM 15/0	HW-F	3			008275 ●
Edging knife	KM 12/1	HW-F	3			008271 ●
Edging knife	KM 11/0	HW-F		45°		008268 ●

Spare parts:

BEZ	ABM mm	ID
Clamping wedge	48x18.75x8.27	009677 ●
Clamping wedge	98x18.75x8.27	009681 ●
Clamping screw w. disc, Torx® 25	M6x18.5	007442 ●
Countersink screw, Torx® 20	M6x35	007098 ●
Torx® key	Torx® 20	117503 ●
Torx® key	Torx® 25	117504 ●
Magnetic setting gauge	0.3/0.8	005376 ●

Order example:

Tool set ID **426000** mounted on arbor ID **041125**, shank 25x60 mm.

When ordering, choose arbors with $d = 20 \text{ mm}$ and clamping length 55 mm.

Rebating cutterset, 2 part design

Application:

For jointing, rebating and grooving.

Machine:

Spindle moulders (running against feed), double-end tenoners and edgebanding machines etc. (running with feed or against feed).

Workpiece material:

Softwood and hardwood, glulam, plastics etc.

Technical information:

2 part with spacers adjustable tool set with alternate shear angle and triangular spurs.

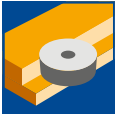

HW

SB 26.4 - 98 mm

SW 531 1 01

D	SB	VSB	BO	BO _{max}	Z	V	n	ID
mm	mm		mm	mm			min ⁻¹	
160	20	26.4 - 38	30	45	4	4	4900 - 9500	024456 ●
160	20	26.4 - 38	50	50	4	4	4900 - 9500	024458 □
160	50	56.4 - 98	40	45	4	4	4900 - 9500	024455

Spare knives:

Part-no.	BEZ	ABM	QAL	VE	ID
		mm		PCS	
1	Turnblade knife	19.7x8x1.5	HW-30F	10	005071 ●
1	Turnblade knife	50x8x1.5	HW-30F	10	005075 ●
1	Turnblade knife	30x8x1.5	HW-30F	10	005072 ●
2	Turnblade spur VS2	19x19x2	HW-F	10	005115 ●

Spare parts:

Part-no.	BEZ	ABM	ID
		mm	
3	Clamping wedge	18x18.75x8.27	009671 ●
3	Clamping wedge	48x18.75x8.27	009677 ●
3	Clamping wedge	28x18.75x8.27	009673 ●
4	Countersink screw, Torx® 20	M6x0.5x4.9	006243 ●
5	Clamping screw w. disc, Torx® 25	M6x18.5	007442 ●
6	Torx® key	Torx® 20	117503 ●
7	Torx® key	Torx® 25	117504 ●
	Setting gauge for knives	0.3/0.8	005374 ●

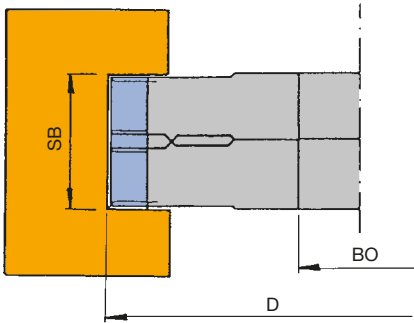

Tool set



Rebating from below



Rebating from above



Grooving

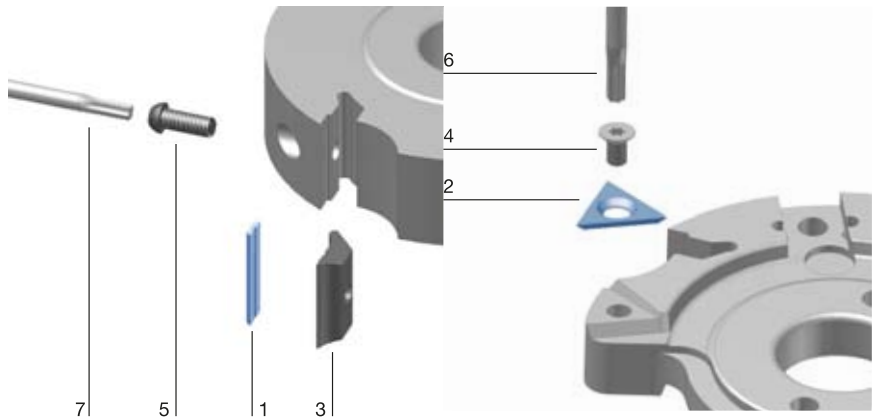

Архангельск (8182)63-90-72
Астана (7172)727-132
Астрахань (8512)99-46-04
Барнаул (3852)73-04-60
Белгород (4722)40-23-64
Брянск (4832)59-03-52
Владивосток (423)249-28-31
Волгоград (844)278-03-48
Вологда (8172)26-41-59
Воронеж (473)204-51-73
Екатеринбург (343)384-55-89
Иваново (4932)77-34-06

Ижевск (3412)26-03-58
Иркутск (395)279-98-46
Казань (843)206-01-48
Калининград (4012)72-03-81
Калуга (4842)92-23-67
Кемерово (3842)65-04-62
Киров (8332)68-02-04
Краснодар (861)203-40-90
Красноярск (391)204-63-61
Курск (4712)77-13-04
Липецк (4742)52-20-81
Киргизия (996)312-96-26-47

Магнитогорск (3519)55-03-13
Москва (495)268-04-70
Мурманск (8152)59-64-93
Набережные Челны (8552)20-53-41
Нижний Новгород (831)429-08-12
Новокузнецк (3843)20-46-81
Новосибирск (383)227-86-73
Омск (3812)21-46-40
Орел (4862)44-53-42
Оренбург (3532)37-68-04
Пенза (8412)22-31-16
Россия (495)268-04-70

Пермь (342)205-81-47
Ростов-на-Дону (863)308-18-15
Рязань (4912)46-61-64
Самара (846)206-03-16
Санкт-Петербург (812)309-46-40
Саратов (845)249-38-78
Севастополь (8692)22-31-93
Симферополь (3652)67-13-56
Смоленск (4812)29-41-54
Сочи (862)225-72-31
Ставрополь (8652)20-65-13
Казахстан (772)734-952-31

Сургут (3462)77-98-35
Тверь (4822)63-31-35
Томск (3822)98-41-53
Тула (4872)74-02-29
Тюмень (3452)66-21-18
Ульяновск (8422)24-23-59
Уфа (347)229-48-12
Хабаровск (4212)92-98-04
Челябинск (351)202-03-61
Череповец (8202)49-02-64
Ярославль (4852)69-52-93