



Profile cutterhead VariForm

Application:

For cutting profiles. Different knives with maximum 15 mm profile depth can be mounted.

Machine:

Spindle moulders and moulders, double-end tenoners, edgebanding machines etc.

Workpiece material:

Softwood and hardwood (HW-30F), panel materials or glued wood (HW-10F).

Technical information:

Multi-purpose profile cutterhead for MAN feed with tungsten carbide special profile knives and backing plates and limitors. Resharpenable 3 to 4 times.



Tool body, MAN feed, Z 2

TT 531 1

D	TD	SB	BO	BO _{max}	PT _{max}	Z	n _{max}	ID
mm	mm	mm	mm	mm	mm		min ⁻¹	
150	116	40 - 45	30	50	15	2	8000	135100 ●
150	116	50 - 60	30	50	15	2	8000	135101 ●

Supplied with clamping wedges, but without backing plates, limitors and knives.

Spare knives:

Part-no.	SB	H	PT _{max}	ID	ID
	mm	mm	mm	HW-10F	HW-30F
1	40	40	15	636227 ●	636240 ●
1	45	40	15	636231 ●	636244 ●
1	50	40	15	636284 ●	636272 ●
1	60	40	15	636288 ●	636276 ●

Spare parts:

Part-no.	BEZ	ABM	for SB	ID
		mm	mm	
2	Backing plate VariForm	for knives 40x40x2.1	40	645000 ●
2	Backing plate VariForm	for knives 45x40x2.1	45	645001 ●
2	Backing plate VariForm	for knives 50x40x2.1	50	645002 ●
2	Backing plate VariForm	for knives 60x40x2.1	60	645003 ●
3	Limiter VariForm	for knives 40x40x2.1		640000 ●
3	Limiter VariForm	for knives 45x40x2.1		640001 ●
3	Limiter VariForm	for knives 50x40x2.1		640002 ●
3	Limiter VariForm	for knives 60x40x2.1		640003 ●
4	Clamping wedge	36x13.21x26	40/45	009756 ●
4	Clamping wedge VariForm	44x13.21x24.25	50/60	009760 ●
5	Allen screw with ISK 5	M10x12		006044 ●
	Allen key	SW 5, L100		117506 ●

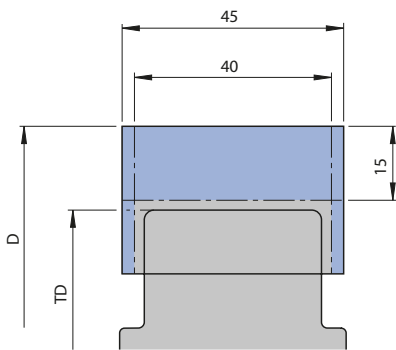

Tool body, SB 40/45 mm

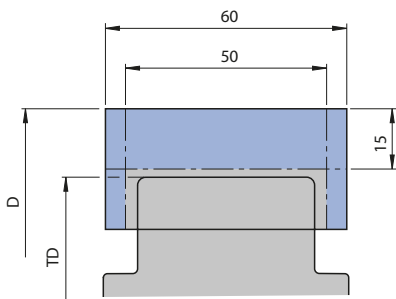

Tool body, SB 50/60 mm

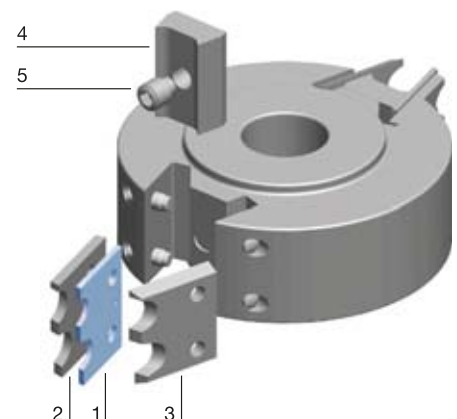

Архангельск (8182)63-90-72
Астана (7172)727-132
Астрахань (8512)99-46-04
Барнаул (3852)73-04-60
Белгород (4722)40-23-64
Брянск (4832)59-03-52
Владивосток (423)249-28-31
Волгоград (844)278-03-48
Вологда (8172)26-41-59
Воронеж (473)204-51-73
Екатеринбург (343)384-55-89
Иваново (4932)77-34-06

Ижевск (3412)26-03-58
Иркутск (395)279-98-46
Казань (843)206-01-48
Калининград (4012)72-03-81
Калуга (4842)92-23-67
Кемерово (3842)65-04-62
Киров (8332)68-02-04
Краснодар (861)203-40-90
Красноярск (391)204-63-61
Курск (4712)77-13-04
Липецк (4742)52-20-81
Киргизия (996)312-96-26-47

Магнитогорск (3519)55-03-13
Москва (495)268-04-70
Мурманск (8152)59-64-93
Набережные Челны (8552)20-53-41
Нижегород (831)429-08-12
Новокузнецк (3843)20-46-81
Новосибирск (383)227-86-73
Омск (3812)21-46-40
Орел (4862)44-53-42
Оренбург (3532)37-68-04
Пенза (8412)22-31-16
Россия (495)268-04-70

Пермь (342)205-81-47
Ростов-на-Дону (863)308-18-15
Рязань (4912)46-61-64
Самара (846)206-03-16
Санкт-Петербург (812)309-46-40
Саратов (845)249-38-78
Севастополь (8692)22-31-93
Симферополь (3652)67-13-56
Смоленск (4812)29-41-54
Сочи (862)225-72-31
Ставрополь (8652)20-65-13
Казахстан (772)734-952-31

Сургут (3462)77-98-35
Тверь (4822)63-31-35
Томск (3822)98-41-53
Тула (4872)74-02-29
Тюмень (3452)66-21-18
Ульяновск (8422)24-23-59
Уфа (347)229-48-12
Хабаровск (4212)92-98-04
Челябинск (351)202-03-61
Череповец (8202)49-02-64
Ярославль (4852)69-52-93

4. Manual feed

4.4 Profiling

4.4.7 Multi-purpose profile cutterheads



Profile cutterhead VariForm

Application:

For cutting profiles. Different knives with maximum 20 mm profile depth can be mounted.

Machine:

Spindle moulders and moulders, double-end tenoners, edgbanding machines etc.

Workpiece material:

Softwood and hardwood (HW-30F), panel materials or glued wood (HW-10F).

Technical information:

Multi-purpose profile cutterhead for MAN feed with tungsten carbide special profile knives and backing plates and limitors. Resharpenable 3 to 4 times.



Part profiled tool body, MAN feed, Z 2 (U-profile).

TT 531 1

D	TD	SB	BO	BO _{max}	PT _{max}	Z	n _{max}	ID
mm	mm	mm	mm	mm	mm		min ⁻¹	
180	165	40	30	50	20	2	7200	135120 ●
180	165	60	30	50	20	2	7200	135122 ●

Supplied with clamping wedges, but without backing plates, limitors and knives.

Spare knives:

Part-no.	SB	H	PT	ID	ID
	mm	mm	mm	HW-10F	HW-30F
1	40	45	20	636226 ●	636239 ●
1	60	45	20	636287 ●	636275 ●

Spare parts:

Part-no.	BEZ	ABM	for SB	ID
		mm	mm	
2	Backing plate VariForm	for knives 40x45x2.1		645004 ●
2	Backing plate VariForm	for knives 60x45x2.1		645006 ●
3	Limiter VariForm	for knives 40x45x2.1		640004 ●
3	Limiter VariForm	for knives 60x45x2.1		640006 ●
4	Clamping wedge	36x13.21x26	40/45	009756 ●
4	Clamping wedge	56x13.21x26	60	009757 ●
5	Allen screw with ISK 5	M10x12		006044 ●
	Allen key	SW 5, L100		117506 ●

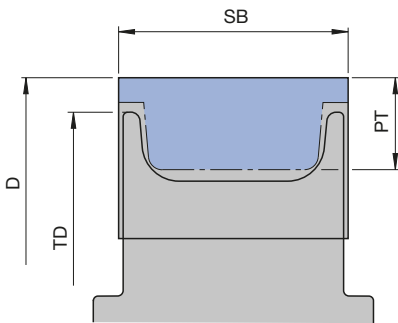

Tool body, U profile

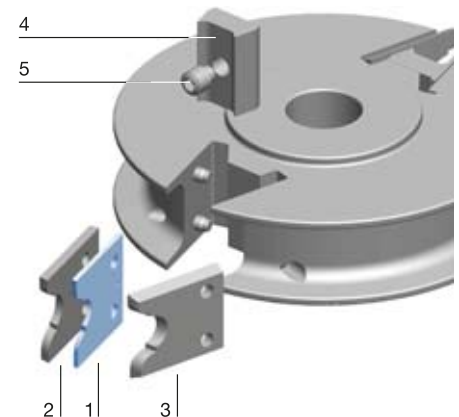

3. Planing and profiling

3.3 Profiling

3.3.3 Cutterheads for multi-purpose profiling



Profile cutterhead VariForm

Application:

For cutting profiles. Different profiles with maximum 20 mm profile depth can be mounted.

Machine:

Moulders, double-end tenoners, edgbanding machines etc.

Workpiece material:

Softwood and hardwood (HW-30F), panel materials or glued wood (HW-10F).

Technical information:

Multi-purpose cutterhead for MEC feed with tungsten carbide special profile knives and backing plates.

Resharpenable 3 to 4 times.

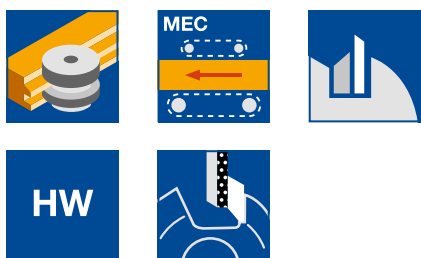

Partly profiled tool body, MEC feed, Z 2 - Z 4 U profile

TT 531 2

D	TD	SB	BO	BO _{max}	PT _{max}	Z	n _{max} min ⁻¹	ID
mm	mm	mm	mm	mm	mm			
165	140	40	30	40	20	2	10000	135212 ●
165	140	60	30	40	20	2	10000	134214 ●
180	165	40	30	50	20	4	9000	135206 ●
180	165	60	30	50	20	4	9000	135208 ●

Supplied with clamping wedges, but without backing plates and knives.

Spare knives:

Part-no.	H	SB	ID	ID
	mm	mm	HW-10F	HW-30F
1	45	40	636226 ●	636239 ●
1	45	60	636287 ●	636275 ●

Spare parts:

Part-no.	BEZ	ABM	for SB	ID
		mm	mm	
2	Backing plate VariForm	for knives 40x45x2.1		645004 ●
2	Backing plate VariForm	for knives 60x45x2.1		645006 ●
3	Clamping wedge	36x13.21x26	40/45	009756 ●
3	Clamping wedge	56x13.21x26	60	009757 ●
4	Allen screw with ISK 5	M10x12		006044 ●
	Allen key	SW 5, L100		117506 ●

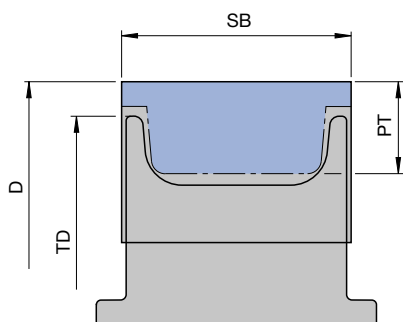

Tool body, U profile

Table of the O-diameter (D₀) for adjusting the machine spindles

D	TD	D ₀
mm	mm	mm
150	135	110
165	140	125
180	165	140

Tool system description VariForm see section Profile Tool Systems.

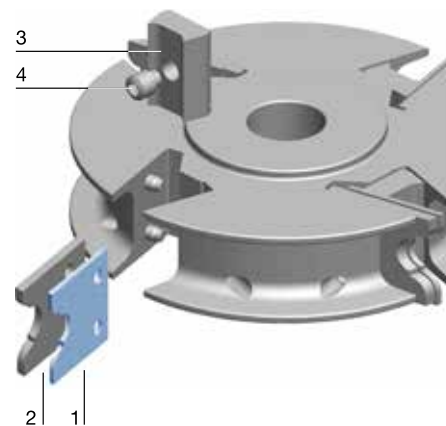

Архангельск (8182)63-90-72
Астана (7172)727-132
Астрахань (8512)99-46-04
Барнаул (3852)73-04-60
Белгород (4722)40-23-64
Брянск (4832)59-03-52
Владивосток (423)249-28-31
Волгоград (844)278-03-48
Вологда (8172)26-41-59
Воронеж (473)204-51-73
Екатеринбург (343)384-55-89
Иваново (4932)77-34-06

Ижевск (3412)26-03-58
Иркутск (395)279-98-46
Казань (843)206-01-48
Калининград (4012)72-03-81
Калуга (4842)92-23-67
Кемерово (3842)65-04-62
Киров (8332)68-02-04
Краснодар (861)203-40-90
Красноярск (391)204-63-61
Курск (4712)77-13-04
Липецк (4742)52-20-81
Киргизия (996)312-96-26-47

Магнитогорск (3519)55-03-13
Москва (495)268-04-70
Мурманск (8152)59-64-93
Набережные Челны (8552)20-53-41
Нижний Новгород (831)429-08-12
Новокузнецк (3843)20-46-81
Новосибирск (383)227-86-73
Омск (3812)21-46-40
Орел (4862)44-53-42
Оренбург (3532)37-68-04
Пенза (8412)22-31-16
Россия (495)268-04-70

Пермь (342)205-81-47
Ростов-на-Дону (863)308-18-15
Рязань (4912)46-61-64
Самара (846)206-03-16
Санкт-Петербург (812)309-46-40
Саратов (845)249-38-78
Севастополь (8692)22-31-93
Симферополь (3652)67-13-56
Смоленск (4812)29-41-54
Сочи (862)225-72-31
Ставрополь (8652)20-65-13
Казахстан (772)734-952-31

Сургут (3462)77-98-35
Тверь (4822)63-31-35
Томск (3822)98-41-53
Тула (4872)74-02-29
Тюмень (3452)66-21-18
Ульяновск (8422)24-23-59
Уфа (347)229-48-12
Хабаровск (4212)92-98-04
Челябинск (351)202-03-61
Череповец (8202)49-02-64
Ярославль (4852)69-52-93