

2. Panel processing

2.1 Edge processing

2.1.7 Edge finishing tools

Profile cutterhead / bevel cutterhead



Application:

To round edgebandings.

Machine:

Single or double-sided edgebanding machines.

Workpiece material:

Plastic, softwood, hardwood and veneer edgebander.

Technical information:

Cutterheads with HW knives and cylindrical bore with DKN. The same cutterhead tool body for R 1.5 to 3.0 mm. D_0 = constant reference diameter.

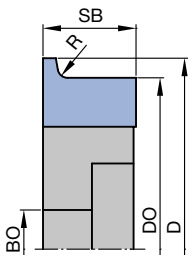
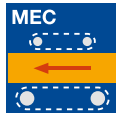

Type 1

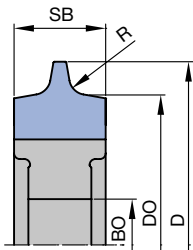

Type 2

Various radii - Brandt

WE 500 2

Machine	D	D_0	SB	BO	Z	R	Type	n_{max}	ID	ID
	mm	mm	mm	mm		mm		min^{-1}	LH	RH
Brandt	56	50	16	16 DKN	4	2	1	18000	075006	075005
Brandt	58	50	12	16 DKN	4	3	2	18000	075004	075004
Brandt	78	70	19	16 DKN	4	3	1	18000	075003	075002
Brandt	82	70	16	16 DKN	4	2	2	18000	075009	075009

Spare knives:

Part-no.	Type	BEZ	ABM	QAL	R	VE	ID	ID
			mm		mm	PCS	LH	RH
1	1	Exchange knife	16x13.4x2	HW	1.5	10	075325 ●	075324 ●
1	1	Exchange knife	16x13.4x2	HW	2.0	10	075327 ●	075326 ●
1	1	Exchange knife	16x13.4x2	HW	3.0	10	075329 ●	075328 ●
1	1	Exchange knife	19.6x15.2x2	HW	1.5	10	075334 ●	075333 ●
1	1	Exchange knife	19.6x15.2x2	HW	2.0	10	075336 ●	075335 ●
1	1	Exchange knife	19.6x15.2x2	HW	2.5	10	075338 ●	075337 ●
1	1	Exchange knife	19.6x15.2x2	HW	3.0	10	075303 ●	075302 ●
1	2	Exchange knife	12x13x2	HW	1.5	10	075339 ●	075339 ●
1	2	Exchange knife	12x13x2	HW	2.0	10	075330 ●	075330 ●
1	2	Exchange knife	12x13x2	HW	3.0	10	075304 ●	075304 ●
1	2	Exchange knife	16x17.5x2	HW	1.5	10	009539 ●	009539 ●
1	2	Exchange knife	16x17.5x2	HW	2.0	10	005132 ●	005132 ●
1	2	Exchange knife	16x17.5x2	HW	3.0	10	005133 ●	005133 ●

Spare parts:

Part-no.	BEZ	ABM	ID
		mm	
2	Clamping wedge	10x11.5x7	075400 ●
2	Clamping wedge	10x10.9x7	075403 ●
2	Clamping wedge	13.5x11x7	075404 ●
2	Clamping wedge	19	075401 ●
2	Clamping wedge	19	075402 ●
3	Allen screw	M6x12	006035 ●
	Allen key	SW 3	005444 ●
	Setting gauge for knives	1.0	005350 ●

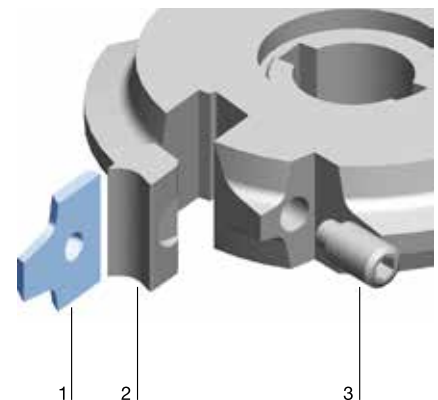

Архангельск (8182)63-90-72
Астана (7172)727-132
Астрахань (8512)99-46-04
Барнаул (3852)73-04-60
Белгород (4722)40-23-64
Брянск (4832)59-03-52
Владивосток (423)249-28-31
Волгоград (844)278-03-48
Волгод (8172)26-41-59
Воронеж (473)204-51-73
Екатеринбург (343)384-55-89
Иваново (4932)77-34-06

Ижевск (3412)26-03-58
Иркутск (395)279-98-46
Казань (843)206-01-48
Калининград (4012)72-03-81
Калуга (4842)92-23-67
Кемерово (3842)65-04-62
Киров (8332)68-02-04
Краснодар (861)203-40-90
Красноярск (391)204-63-61
Курск (4712)77-13-04
Липецк (4742)52-20-81
Киргизия (996)312-96-26-47

Магнитогорск (3519)55-03-13
Москва (495)268-04-70
Мурманск (8152)59-64-93
Набережные Челны (8552)20-53-41
Нижний Новгород (831)429-08-12
Новокузнецк (3843)20-46-81
Новосибирск (383)227-86-73
Омск (3812)21-46-40
Орел (4862)44-53-42
Оренбург (3532)37-68-04
Пенза (8412)22-31-16
Россия (495)268-04-70

Пермь (342)205-81-47
Ростов-на-Дону (863)308-18-15
Рязань (4912)46-61-64
Самара (846)206-03-16
Санкт-Петербург (812)309-46-40
Саратов (845)249-38-78
Севастополь (8692)22-31-93
Симферополь (3652)67-13-56
Смоленск (4812)29-41-54
Сочи (862)225-72-31
Ставрополь (8652)20-65-13
Казахстан (772)734-952-31

Сургут (3462)77-98-35
Тверь (4822)63-31-35
Томск (3822)98-41-53
Тула (4872)74-02-29
Тюмень (3452)66-21-18
Ульяновск (8422)24-23-59
Уфа (347)229-48-12
Хабаровск (4212)92-98-04
Челябинск (351)202-03-61
Череповец (8202)49-02-64
Ярославль (4852)69-52-93

2. Panel processing

2.1 Edge processing

2.1.7 Edge finishing tools

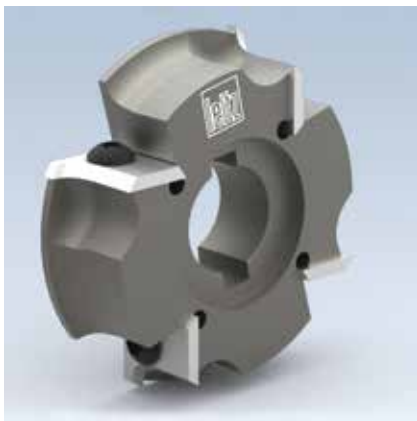

Profile cutterhead / bevel cutterhead

Application:

To round edgebandings.

Machine:

Single or double-sided edgebanding machines.

Workpiece material:

Plastic, softwood, hardwood and veneer edgebander.

Technical information:

Cutterheads with HW knives and cylindrical bore with DKN. One cutterhead basic body for R 1.5 to 3.0 mm. D_0 = constant reference diameter.

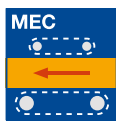
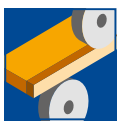

Various radii - Hebrock/EBM

WE 500 2

Machine	D	D ₀	SB	BO	Z	R	Type	n _{max}	ID	ID
	mm	mm	mm	mm		mm		min ⁻¹	LH	RH
Hebrock/EBM	56	49.7	14.5	16 DKN	4	2.0	1	18000	074559	074560
Hebrock/EBM	56	49.7	14.5	16 DKN	4	2.5	1	18000	074557	074558

Spare knives:

Part-no.	Type	BEZ	ABM	QAL	R	VE	ID	ID
			mm			PCS	LH	RH
1	1	Combi exchange knife	14.5x14.5x2	HW	2.0	10	074632	074633
1	1	Combi exchange knife	14.5x14.5x2	HW	2.5	10	074630	074631

Spare parts:

Part-no.	BEZ	ABM	ID
		mm	
2	Screw	M3.5x8	005723

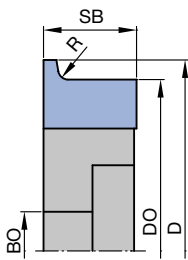

Type 1

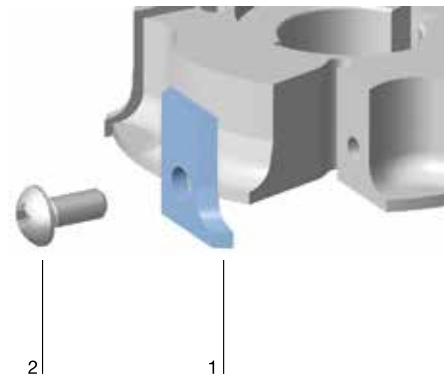

2. Panel processing

2.1 Edge processing 2.1.7 Edge finishing tools



Profile cutterhead / bevel cutterhead

Application:

To round and bevel edgebandings.

Machine:

Single or double-sided edgebanding machines. Machines must be equipped with DFC system.

Workpiece material:

Plastic, softwood, hardwood and veneer edgebander.

Technical information:

Cutterheads with HW knives and cylindrical bore with DKN. D_0 = constant reference diameter. DFC design for highly efficient chip clearance of more than 97%.

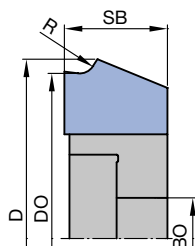
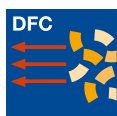
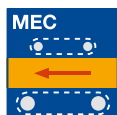

Various profiles - DFC, Brandt

WE 500 2

Machine	D	SB	BO	Z	R	FAW	Type	n_{max}	ID	ID
	mm	mm	mm		mm	°		min^{-1}	LH	RH
Brandt	70.23	20.28	16 DKN	4		15°	1	12000	075012	075013
Brandt	70.23	20.28	16 DKN	4		30°	1	12000	075014	075015
Brandt	69.98	20.28	16 DKN	4		45°	1	12000	075016	075017
Brandt	70.57	20.28	16 DKN	4	1.0		1	12000	075018	075019
Brandt	70.57	20.28	16 DKN	4	1.2		1	12000	075020	075021
Brandt	70.57	20.28	16 DKN	4	1.3		1	12000	075072	075073
Brandt	70.57	20.28	16 DKN	4	1.5		1	12000	075022	075023
Brandt	70.57	20.28	16 DKN	4	2.0		1	12000	075024	075025
Brandt	70.57	20.28	16 DKN	4	2.5		1	12000	075026	075027
Brandt	70.57	20.28	16 DKN	4	3.0		1	12000	075028	075029

Spare knives:

Part-no.	Type	BEZ	ABM	QAL	R	FAW	VE	ID	ID
			mm		mm	°	PCS	LH	RH
1	1	Exchange knife	22.3x14x2	HW	1.0	10	10	075315	075314
1	1	Exchange knife	22.3x14x2	HW	1.2	10	10	075317	075316
1	1	Exchange knife	22.3x14x2	HW	1.3	10	10	075272	075271
1	1	Exchange knife	22.3x14x2	HW	1.5	10	10	075319	075318
1	1	Exchange knife	22.3x14x2	HW	2.0	10	10	075307	075306
1	1	Exchange knife	22.3x14x2	HW	2.5	10	10	075321	075320
1	1	Exchange knife	22.3x14x2	HW	3.0	10	10	075309	075308
1	1	Exchange knife	22.3x14x2	HW		15°	10	075311	075310
1	1	Exchange knife	22.3x14x2	HW		30°	10	075331	075332
1	1	Exchange knife	22.3x14x2	HW		45°	10	075313	075312

Spare parts:

Part-no.	BEZ	ABM	ID
		mm	
2	Oval head screw Torx® 15	M4x6	006225
	Torx® key	Torx® 15	005466

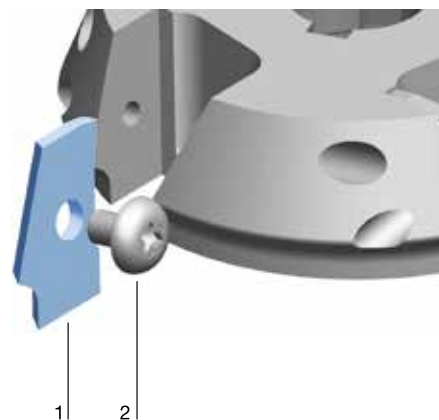

Архангельск (8182)63-90-72
Астана (7172)727-132
Астрахань (8512)99-46-04
Барнаул (3852)73-04-60
Белгород (4722)40-23-64
Брянск (4832)59-03-52
Владивосток (423)249-28-31
Волгоград (844)278-03-48
Вологда (8172)26-41-59
Воронеж (473)204-51-73
Екатеринбург (343)384-55-89
Иваново (4932)77-34-06

Ижевск (3412)26-03-58
Иркутск (395)279-98-46
Казань (843)206-01-48
Калининград (4012)72-03-81
Калуга (4842)92-23-67
Кемерово (3842)65-04-62
Киров (8332)68-02-04
Краснодар (861)203-40-90
Красноярск (391)204-63-61
Курск (4712)77-13-04
Липецк (4742)52-20-81
Киргизия (996)312-96-26-47

Магнитогорск (3519)55-03-13
Москва (495)268-04-70
Мурманск (8152)59-64-93
Набережные Челны (8552)20-53-41
Нижний Новгород (831)429-08-12
Новокузнецк (3843)20-46-81
Новосибирск (383)227-86-73
Омск (3812)21-46-40
Орел (4862)44-53-42
Оренбург (3532)37-68-04
Пенза (8412)22-31-16
Россия (495)268-04-70

Пермь (342)205-81-47
Ростов-на-Дону (863)308-18-15
Рязань (4912)46-61-64
Самара (846)206-03-16
Санкт-Петербург (812)309-46-40
Саратов (845)249-38-78
Севастополь (8692)22-31-93
Симферополь (3652)67-13-56
Смоленск (4812)29-41-54
Сочи (862)225-72-31
Ставрополь (8652)20-65-13
Казахстан (772)734-952-31

Сургут (3462)77-98-35
Тверь (4822)63-31-35
Томск (3822)98-41-53
Тула (4872)74-02-29
Тюмень (3452)66-21-18
Ульяновск (8422)24-23-59
Уфа (347)229-48-12
Хабаровск (4212)92-98-04
Челябинск (351)202-03-61
Череповец (8202)49-02-64
Ярославль (4852)69-52-93