

4. Manual feed

4.1 Grooving

4.1.1 Grooving cutters



Grooving cutters for manual feed

Application:

For grooving with (MEC) or against feed (MAN).

Machine:

Spindle moulders, moulders and double-end tenoners.

Workpiece material:

Solid wood; uncoated, coated and veneered wood derived materials.

Technical information:

Tool body design with round, closed shape.

Z 12

WF 100 1 05

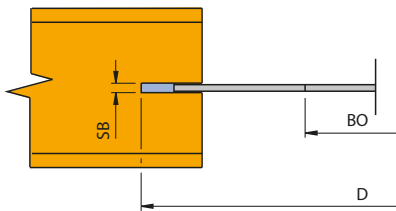

Scheme: Grooving in middle layer

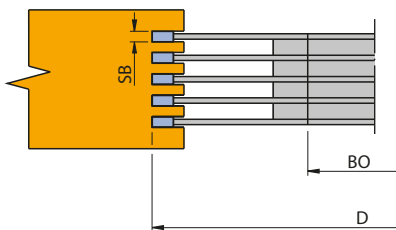

Scheme: Set assembly for lock corner joint

D mm	SB mm	TDI mm	BO mm	BO _{max} mm	Z	n min ⁻¹	ID
125	1.5	0.8	30	50	12	6200 - 13700	020241 ●
125	2.0	1.2	30	50	12	6200 - 13700	020243 ●
125	2.5	1.4	30	50	12	6200 - 13700	020245 ●
125	3.0	2.0	30	50	12	6200 - 13700	020246 ●
125	3.5	2.2	30	50	12	6200 - 13700	020247 ●
125	4.0	2.5	30	50	12	6200 - 13700	020248 ●
125	4.5	3.0	30	50	12	6200 - 13700	020249 ●
150	1.5	0.8	30	60	12	5200 - 11400	020265 ●
150	2.0	1.2	30	60	12	5200 - 11400	020267 ●
150	2.5	1.4	30	60	12	5200 - 11400	020269 ●
150	3.0	2.0	30	60	12	5200 - 11400	020250 ●
150	3.5	2.2	30	60	12	5200 - 11400	020251 ●
150	4.0	2.5	30	60	12	5200 - 11400	020252 ●
150	4.5	3.0	30	60	12	5200 - 11400	020253 ●
150	5.0	3.5	30	60	12	5200 - 11400	020254 ●
150	6.0	4.5	30	60	12	5200 - 11400	020255 ●
150	7.0	5.0	30	60	12	5200 - 11400	020256 ●
150	8.0	6.0	30	60	12	5200 - 11400	020257 ●
150	9.0	7.0	30	60	12	5200 - 11400	160100 ●
150	10.0	8.0	30	60	12	5200 - 11400	160101 ●
180	4.0	2.5	30	70	12	4300 - 9500	020260 ●
180	5.0	3.5	30	70	12	4300 - 9500	020261 ●
180	6.0	4.5	30	70	12	4300 - 9500	020262 ●
180	8.0	6.0	30	70	12	4300 - 9500	020263 ●
180	10.0	8.0	30	70	12	4300 - 9500	160102 ●

Groove cutter for MEC, see section Panel Processing.

For spacers TR 100 0 used as a set, see section Knives and Spare Parts.

Архангельск (8182)63-90-72
Астана (7172)727-132
Астрахань (8512)99-46-04
Барнаул (3852)73-04-60
Белгород (4722)40-23-64
Брянск (4832)59-03-52
Владивосток (423)249-28-31
Волгоград (844)278-03-48
Вологда (8172)26-41-59
Воронеж (473)204-51-73
Екатеринбург (343)384-55-89
Иваново (4932)77-34-06

Ижевск (3412)26-03-58
Иркутск (395)279-98-46
Казань (843)206-01-48
Калининград (4012)72-03-81
Калуга (4842)92-23-67
Кемерово (3842)65-04-62
Киров (8332)68-02-04
Краснодар (861)203-40-90
Красноярск (391)204-63-61
Курск (4712)77-13-04
Липецк (4742)52-20-81
Киргизия (996)312-96-26-47

Магнитогорск (3519)55-03-13
Москва (495)268-04-70
Мурманск (8152)59-64-93
Набережные Челны (8552)20-53-41
Нижний Новгород (831)429-08-12
Новокузнецк (3843)20-46-81
Новосибирск (383)227-86-73
Омск (3812)21-46-40
Орел (4862)44-53-42
Оренбург (3532)37-68-04
Пенза (8412)22-31-16
Россия (495)268-04-70

Пермь (342)205-81-47
Ростов-на-Дону (863)308-18-15
Рязань (4912)46-61-64
Самара (846)206-03-16
Санкт-Петербург (812)309-46-40
Саратов (845)249-38-78
Севастополь (8692)22-31-93
Симферополь (3652)67-13-56
Смоленск (4812)29-41-54
Сочи (862)225-72-31
Ставрополь (8652)20-65-13
Казахстан (772)734-952-31

Сургут (3462)77-98-35
Тверь (4822)63-31-35
Томск (3822)98-41-53
Тула (4872)74-02-29
Тюмень (3452)66-21-18
Ульяновск (8422)24-23-59
Уфа (347)229-48-12
Хабаровск (4212)92-98-04
Челябинск (351)202-03-61
Череповец (8202)49-02-64
Ярославль (4852)69-52-93



Grooving cutter - lamello joints

Application:

For grooving lamello joints and for cutting grooves for corner joints and longitudinal joints (e.g. picture frames, furniture doors).

Machine:

Portable power tools - grooving cutters (e.g. Lamello etc.).

Workpiece material:

Solid wood; uncoated, coated and veneered wood derived materials.

Technical information:

Tool body design with round, closed shape.

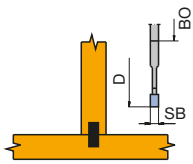

Lamello - T-joint

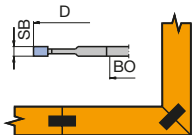

Lamello - Longitudinal/corner joint

HW tipped

WF 102 1 01

D	SB	BO	NLA	Z	V	QAL	n	ID
mm	mm	mm	mm				min ⁻¹	
100	4.0	22	4/4.5/36	2	4	HW	7800 - 13300	020124 ●

DP tipped

WF 100 1 DP

D	SB	BO	NLA	Z	QAL	n	ID
mm	mm	mm	mm			min ⁻¹	
100	4	22	4/4.5/36	4	DP	7800 - 13300	090017 ●

Grooving cutterhead

WW 102 1 01

D	SB	BO	NLA	Z	V	QAL	n	ID
mm	mm	mm	mm				min ⁻¹	
100	4	22	4/4.5/36	2/2	2/2	HW	7800 - 13300	020131 ●

Spare knives:

Part-no.	BEZ	QAL	VE	ID
			PCS	
1	Turnblade knife	HW	10	005114 ●
2	Turnblade spur VS4	HW	10	005130 ●

Spare parts:

Part-no.	BEZ	ABM	ID
		mm	
3	Special nut for VS	M9.9/1.60	005654 ●
4	Special nut for WPL	M11.9/2.20	005653 ●
5	Countersink screw, Torx® 9	M4x0.5x3.2	006057 ●
6	Torx® key	Torx® 9	005463 ●

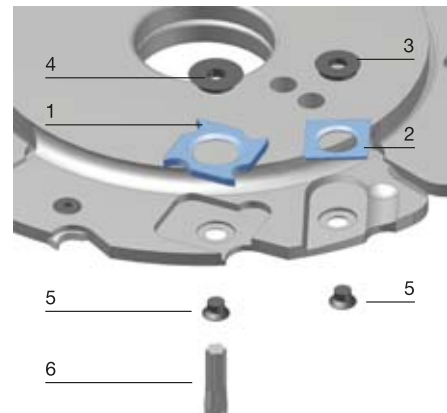

Архангельск (8182)63-90-72
Астана (7172)727-132
Астрахань (8512)99-46-04
Барнаул (3852)73-04-60
Белгород (4722)40-23-64
Брянск (4832)59-03-52
Владивосток (423)249-28-31
Волгоград (844)278-03-48
Вологда (8172)26-41-59
Воронеж (473)204-51-73
Екатеринбург (343)384-55-89
Иваново (4932)77-34-06

Ижевск (3412)26-03-58
Иркутск (395)279-98-46
Казань (843)206-01-48
Калининград (4012)72-03-81
Калуга (4842)92-23-67
Кемерово (3842)65-04-62
Киров (8332)68-02-04
Краснодар (861)203-40-90
Красноярск (391)204-63-61
Курск (4712)77-13-04
Липецк (4742)52-20-81
Киргизия (996)312-96-26-47

Магнитогорск (3519)55-03-13
Москва (495)268-04-70
Мурманск (8152)59-64-93
Набережные Челны (8552)20-53-41
Нижний Новгород (831)429-08-12
Новокузнецк (3843)20-46-81
Новосибирск (383)227-86-73
Омск (3812)21-46-40
Орел (4862)44-53-42
Оренбург (3532)37-68-04
Пенза (8412)22-31-16
Россия (495)268-04-70

Пермь (342)205-81-47
Ростов-на-Дону (863)308-18-15
Рязань (4912)46-61-64
Самара (846)206-03-16
Санкт-Петербург (812)309-46-40
Саратов (845)249-38-78
Севастополь (8692)22-31-93
Симферополь (3652)67-13-56
Смоленск (4812)29-41-54
Сочи (862)225-72-31
Ставрополь (8652)20-65-13
Казахстан (772)734-952-31

Сургут (3462)77-98-35
Тверь (4822)63-31-35
Томск (3822)98-41-53
Тула (4872)74-02-29
Тюмень (3452)66-21-18
Ульяновск (8422)24-23-59
Уфа (347)229-48-12
Хабаровск (4212)92-98-04
Челябинск (351)202-03-61
Череповец (8202)49-02-64
Ярославль (4852)69-52-93