

## 2. Panel processing

## 2.1 Edge processing

### 2.1.7 Edge finishing tools



### Bevel cutter

#### Application:

To bevel edgebandings.

#### Machine:

Single or double-sided edgebanding machines.

#### Workpiece material:

Plastic, softwood, hardwood and veneer edgebander.

#### Technical information:

DP tipped tools with cylindrical bore, HSK 25 R or HSK 32 adaptor for FK aggregates.

DP tools - 3 mm tip height.

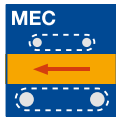
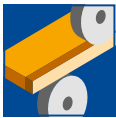

#### Various bevel angles - DP tipped

WF 300 2 DP, WF 350 2 DP

Machine	D mm	SB mm	BO mm	Type	Z	QAL	FAW °	ID LH	ID RH
Biesse	67.2	9	16 DKN	5	6	DP	25°	091976	091975
Biesse	67.2	9	20 DKN	5	6	DP	25°	091970	091969
Biesse	68	9	16 DKN	5	6	DP	45°	091978	091977
Biesse	68	9	20 DKN	5	6	DP	45°	091972	091971
Biesse	80	10.5	16 DKN	6	4	DP	15°	091974	091973
Holz-Her 1825	52	6	16 DKN	3	2	DP	15°	091982	091981
Holz-Her 1832	53	8	16 DKN	3	3	DP	15°	091986	091985
Holz-Her 1832	56	5	16 DKN	3	3	DP	45°	091988	091987
Holz-Her 1833	72.5	8	20 DKN	4	4	DP	45°	091984	091983
Homag	62	5	HSK 32	2	4	DP	20°	091518	091519
Homag	62	5	HSK 32	2	6	DP	20°	091658	091659
Homag	62	5	HSK 32	2	6	DP	30°	091690	091691
Homag	62	5	HSK 32	2	6	DP	45°	091692	091693
Homag	75	8	HSK 25 R	1	4	DP	20°	091790	091791
IMA	75	8	HSK 25 R	1	4	DP	20°	091790	091791
Stefani	70	5	12 DKN	3	4	DP	20°	091980	091979

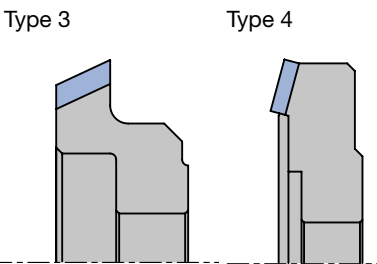
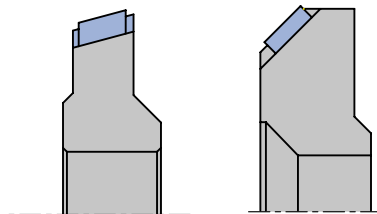
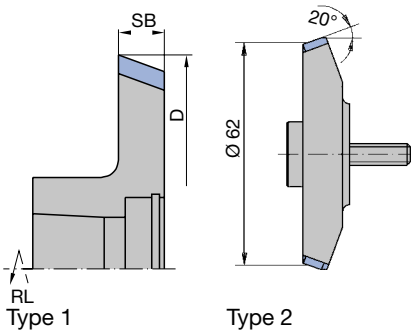

Архангельск (8182)63-90-72  
Астана (7172)727-132  
Астрахань (8512)99-46-04  
Барнаул (3852)73-04-60  
Белгород (4722)40-23-64  
Брянск (4832)59-03-52  
Владивосток (423)249-28-31  
Волгоград (844)278-03-48  
Вологда (8172)26-41-59  
Воронеж (473)204-51-73  
Екатеринбург (343)384-55-89  
Иваново (4932)77-34-06

Ижевск (3412)26-03-58  
Иркутск (395)279-98-46  
Казань (843)206-01-48  
Калининград (4012)72-03-81  
Калуга (4842)92-23-67  
Кемерово (3842)65-04-62  
Киров (8332)68-02-04  
Краснодар (861)203-40-90  
Красноярск (391)204-63-61  
Курск (4712)77-13-04  
Липецк (4742)52-20-81  
Киргизия (996)312-96-26-47

Магнитогорск (3519)55-03-13  
Москва (495)268-04-70  
Мурманск (8152)59-64-93  
Набережные Челны (8552)20-53-41  
Нижний Новгород (831)429-08-12  
Новокузнецк (3843)20-46-81  
Новосибирск (383)227-86-73  
Омск (3812)21-46-40  
Орел (4862)44-53-42  
Оренбург (3532)37-68-04  
Пенза (8412)22-31-16  
Россия (495)268-04-70

Пермь (342)205-81-47  
Ростов-на-Дону (863)308-18-15  
Рязань (4912)46-61-64  
Самара (846)206-03-16  
Санкт-Петербург (812)309-46-40  
Саратов (845)249-38-78  
Севастополь (8692)22-31-93  
Симферополь (3652)67-13-56  
Смоленск (4812)29-41-54  
Сочи (862)225-72-31  
Ставрополь (8652)20-65-13  
Казахстан (772)734-952-31

Сургут (3462)77-98-35  
Тверь (4822)63-31-35  
Томск (3822)98-41-53  
Тула (4872)74-02-29  
Тюмень (3452)66-21-18  
Ульяновск (8422)24-23-59  
Уфа (347)229-48-12  
Хабаровск (4212)92-98-04  
Челябинск (351)202-03-61  
Череповец (8202)49-02-64  
Ярославль (4852)69-52-93

## 2. Panel processing

### 2.1 Edge processing 2.1.7 Edge finishing tools

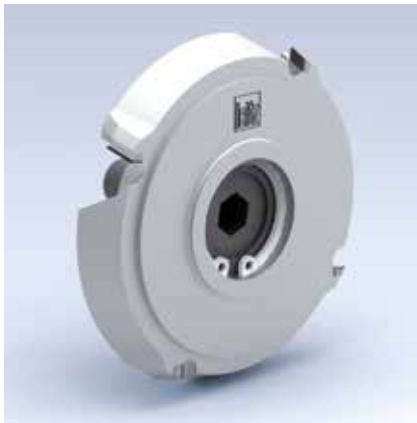

#### Bevel cutter *iQ-system*

**Application:**  
To bevel edgebandings.

**Machine:**  
Single or double-sided edgebanding machines. Machines combined with special extraction hood i-System for efficient chip clearance.

**Workpiece material:**  
Plastic, softwood, hardwood and veneer edgebander.

**Technical information:**  
DP tipped tools with HSK 25 R or HSK 32 adaptor for FK aggregates combined with special extraction hoods i-System for highly efficient chip collection (approx. 97%) with reduced extraction energy consumption. Clean workpieces, no interference with scanning aggregates and less rework. High concentricity. Constant reference diameter.  
DP tools - 3 mm tip height.

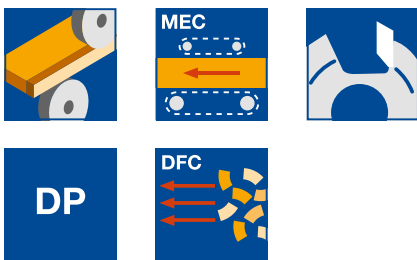

#### Various bevel angles *iQ-system* - Diamaster PRO

WF 350 2 DP

Machine	D <sub>0</sub> mm	SB mm	BO mm	Z	QAL	FAW °	NH mm	ID LH	ID RH
Homag	62	5	HSK 32	4	DP	20°	31.5	<b>198200</b> ●	<b>198201</b> ●
Homag	62	5	HSK 32	4	DP	45°	31.5	<b>198240</b> ●	<b>198241</b> ●
Homag	62	5	HSK 32	6	DP	20°	31.5	<b>198202</b> ●	<b>198203</b> ●
Homag	62	5	HSK 32	6	DP	45°	31.5	<b>198242</b> ●	<b>198243</b> ●
Homag	70	8	HSK 25 R	4	DP	20°	19.5	<b>198408</b> ●	<b>198409</b> ●
Homag	70	8	HSK 25 R	4	DP	45°	19.5	<b>198464</b> ●	<b>198465</b> ●
Homag	70	8	HSK 25 R	6	DP	20°	19.5	<b>198410</b> ●	<b>198411</b> ●
Homag	70	8	HSK 25 R	6	DP	45°	19.5	<b>198466</b> ●	<b>198467</b> ●
IMA	70	8	HSK 25 R	4	DP	20°	19.5	<b>198408</b> ●	<b>198409</b> ●
IMA	70	8	HSK 25 R	4	DP	45°	19.5	<b>198464</b> ●	<b>198465</b> ●
IMA	70	8	HSK 25 R	6	DP	20°	19.5	<b>198410</b> ●	<b>198411</b> ●
IMA	70	8	HSK 25 R	6	DP	45°	19.5	<b>198466</b> ●	<b>198467</b> ●

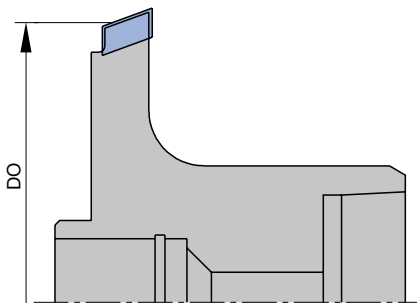

Bevel cutter with HSK 32 adaptor for FK aggregates



## WhisperCut jointing / milling cutter - cutterhead design

### Application:

For tear-free and low noise jointing of workpiece edges side with and against feed (jump cutting).

### Machine:

Edgebanding machines, copy shaping machines, double-end tenoners etc.

### Workpiece material:

Chip and fibre board (MDF etc.) uncoated, veneered, plastic and paper coated, fibre reinforced plastics (GFRP, CFRP etc.).

### Technical information:

DP tipped cutterhead with alternate shear angle for tear-free jointing edges and cutting surfaces. Tool with knife arrangement S can be used left and right and produces hollow cut for tightly closing edgebanding. Low noise design with up to 5 dB(A) noise reduction and highly efficient chip collection (>95%) by DFC. Significant weight reduction by using an aluminium alloy tool body. Carrier body for multiple use with exchangeable knives. 0.6 mm resharpening area.

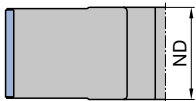
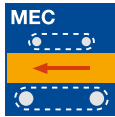

Position of boss (NAL) 1

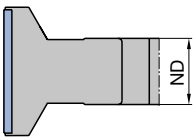

Position of boss (NAL) 2

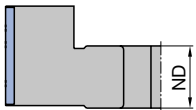

Position of boss (NAL) 3

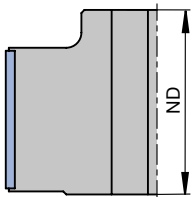

Position of boss (NAL) 4

### Diamaster WhisperCut - DFC, LowNoise, aluminium alloy tool body

WF 230 2 DP, WM 230 2 01

Machine	D mm	SB mm	ND mm	BO mm	NAL	Z	Knife Type	Type	ID LH	ID RH
Biesse	80	45	53	30	DKN 1	2x4	8xB	S	192127 ●	192127 ●
Biesse	80	65	53	30	DKN 2	2x6	12xB	S	192128 ●	192128 ●
Biesse	100	43	75	30	DKN 1	3x4	12xA	S	192088 ●	192088 ●
Biesse	100	65	75	30	DKN 1	3x6	18xA	S	192089 ●	192089 ●
Biesse	125	43	40	30	DKN 2	3x4	12xE	S	075627 ●	075627 ●
Biesse	125	63	40	30	DKN 2	3x6	18xE	S	075626 ●	075626 ●
Brandt	100	43.6	40.6	25	DKN 3	2x4	8xA	AS	192211 ●	192212 ●
Brandt	100	43.6	40.6	30	DKN 3	3x4	12xA	AS	090885 ●	090886 ●
Brandt	100	65.2	40.6	30	DKN 3	3x6	18xA	AS	090887 ●	090888 ●
Brandt	100	85	85	30	DKN 3	3x8	24xA	AS	090889	090890
Brandt	100	105	85	30	DKN 3	3x10	30xA	AS	090891	090892
Cehisa	100	54	25	20	DKN 2	2x5	10xA	AS	192078 ●	192079 ●
Felder	60	63	63.5	25	DKN 3	2x7	12xC	AS°		192278 ●
							2xC2			
Felder	60	63	63.5	25	DKN 3	2x7	12xC	AS°	192277 ●	
							2xC1			
Felder	80	48.5	64	25	DKN 3	3x6	12xF	AS°	192281 ●	192282 ●
							3xB1			
							3xB2			
Felder	80	64	64	25	DKN 3	2x7	12xF	AS°		192300 ●
							2xB2			
Felder	80	64	64	25	DKN 3	2x7	12xF	AS°	192299 ●	
							2xB1			
Felder	80	64	64	25	DKN 3	3x7	18xF	AS°	192279 ●	
							3xB1			
Felder	80	64	64	25	DKN 3	3x7	18xF	AS°		192280 ●
							3xB2			
Fraval	60	63	63.5	25	DKN 3	2x7	12xC	AS°		192248 ●
							2xC2			
Fraval	60	63	63.5	25	DKN 3	2x7	12xC	AS°	192247 ●	
							2xC1			
Fraval	60	84	61	25	DKN 3	2x8	14xC	AS°		192242 ●
							2xC2			
Fraval	60	84	61	25	DKN 3	2x8	14xC	AS°	192241 ●	
							2xC1			
Fraval	100	65	56.5	30	DKN 3	2x6	12xA	AS	192243 ●	192244 ●
Fraval	100	84	56.5	30	DKN 3	2x8	14xA	AS°		192286 ●
							14xA2			
Fraval	100	84	56.5	30	DKN 3	2x8	14xA	AS°	192285 ●	
							14xA1			

Архангельск (8182)63-90-72  
Астана (7172)727-132  
Астрахань (8512)99-46-04  
Барнаул (3852)73-04-60  
Белгород (4722)40-23-64  
Брянск (4832)59-03-52  
Владивосток (423)249-28-31  
Волгоград (844)278-03-48  
Вологда (8172)26-41-59  
Воронеж (473)204-51-73  
Екатеринбург (343)384-55-89  
Иваново (4932)77-34-06

Ижевск (3412)26-03-58  
Иркутск (395)279-98-46  
Казань (843)206-01-48  
Калининград (4012)72-03-81  
Калуга (4842)92-23-67  
Кемерово (3842)65-04-62  
Киров (8332)68-02-04  
Краснодар (861)203-40-90  
Красноярск (391)204-63-61  
Курск (4712)77-13-04  
Липецк (4742)52-20-81  
Киргизия (996)312-96-26-47

Магнитогорск (3519)55-03-13  
Москва (495)268-04-70  
Мурманск (8152)59-64-93  
Набережные Челны (8552)20-53-41  
Нижний Новгород (831)429-08-12  
Новокузнецк (3843)20-46-81  
Новосибирск (383)227-86-73  
Омск (3812)21-46-40  
Орел (4862)44-53-42  
Оренбург (3532)37-68-04  
Пенза (8412)22-31-16  
Россия (495)268-04-70

Пермь (342)205-81-47  
Ростов-на-Дону (863)308-18-15  
Рязань (4912)46-61-64  
Самара (846)206-03-16  
Санкт-Петербург (812)309-46-40  
Саратов (845)249-38-78  
Севастополь (8692)22-31-93  
Симферополь (3652)67-13-56  
Смоленск (4812)29-41-54  
Сочи (862)225-72-31  
Ставрополь (8652)20-65-13  
Казахстан (772)734-952-31

Сургут (3462)77-98-35  
Тверь (4822)63-31-35  
Томск (3822)98-41-53  
Тула (4872)74-02-29  
Тюмень (3452)66-21-18  
Ульяновск (8422)24-23-59  
Уфа (347)229-48-12  
Хабаровск (4212)92-98-04  
Челябинск (351)202-03-61  
Череповец (8202)49-02-64  
Ярославль (4852)69-52-93