



Shank 10 mm, double furniture hinge

Application:

For drilling hinges and pivots in window manufacturing in single or twin drill design.

Machine:

Stationary routers with/without CNC control, machining centres, special boring machines for frame production, automatic boring machines, multi spindle units.

Workpiece material:

Softwood and hardwood, modified timber for window construction, laminated veneer lumber (plywood, multiplex plywood etc.), glued lumber.

Technical information:

Round spur geometry for high edge quality. Solid tungsten carbide design (ID **037218** / **037219** TC-tipped). High wear resistant tungsten carbide grade. Minimum distance of drill spindle 22 mm. ID **037218** / **037219** with pre-drill for corner pivots with pilot pin.



Boring bit set, consisting of 1 pc. RH and LH

AB 710 0

| D | D1 | GL | L | S | QAL | DRI | ID |
|----|----|----|------|-------|----------|--------|-----------------|
| mm | mm | mm | mm | mm | | | |
| 34 | | 57 | 54.5 | 10x23 | HW solid | LH, RH | 036784 □ |
| 30 | | 57 | 54.5 | 10x23 | HW solid | LH, RH | 036785 □ |
| 30 | 8 | 66 | 64 | 10x23 | HW | LH, RH | 036786 |

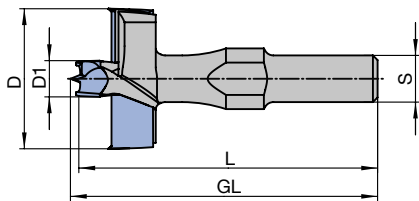

Double hinge drill with pre-drill

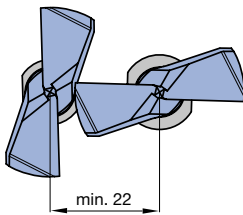

Universally applicable for drilling hinges and pivots on machines and aggregates of the following manufacturers: Weinig, SCM, Ganner, Götzinger, Striffler etc.

GL 57 mm, Z 2 / V 2, single tool

WB 203 0, WB 310 0 13

| D | D1 | GL | L | S | QAL | ID | ID |
|----|----|----|------|-------|----------|-----------------|-----------------|
| mm | mm | mm | mm | mm | | LH | RH |
| 34 | | 57 | 54.5 | 10x23 | HW solid | 034839 ● | 034838 ● |
| 30 | | 57 | 54.5 | 10x23 | HW solid | 037216 ● | 037217 ● |
| 30 | 8 | 66 | 64 | 10x23 | HW | 037218 | 037219 |

RPM: n = 3000 - 9000 min⁻¹

Spare parts:

| BEZ | ABM | BEM | ID |
|------------------------|-------|-------------------|-----------------|
| | mm | | |
| Allen screw | M5x10 | Length adjustment | 005802 ● |
| Anti-twist allen screw | M5x10 | Length adjustment | 007438 ● |

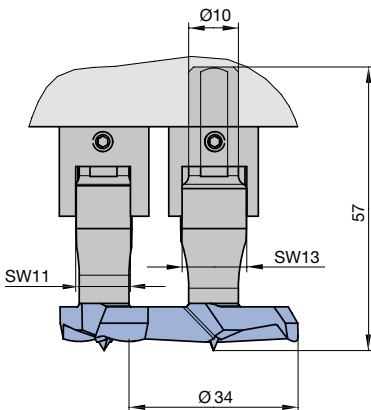

Double hinge drills in aggregate

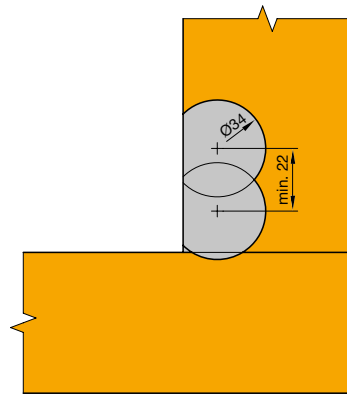

Application example:
Double hinges for corner pivots.

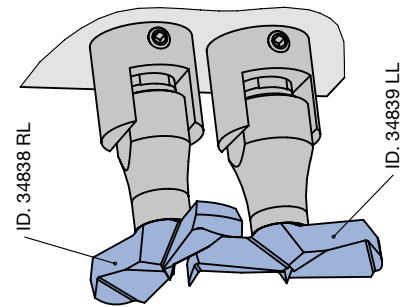

Архангельск (8182)63-90-72
Астана (7172)727-132
Астрахань (8512)99-46-04
Барнаул (3852)73-04-60
Белгород (4722)40-23-64
Брянск (4832)59-03-52
Владивосток (423)249-28-31
Волгоград (844)278-03-48
Вологда (8172)26-41-59
Воронеж (473)204-51-73
Екатеринбург (343)384-55-89
Иваново (4932)77-34-06

Ижевск (3412)26-03-58
Иркутск (395)279-98-46
Казань (843)206-01-48
Калининград (4012)72-03-81
Калуга (4842)92-23-67
Кемерово (3842)65-04-62
Киров (8332)68-02-04
Краснодар (861)203-40-90
Красноярск (391)204-63-61
Курск (4712)77-13-04
Липецк (4742)52-20-81
Киргизия (996)312-96-26-47

Магнитогорск (3519)55-03-13
Москва (495)268-04-70
Мурманск (8152)59-64-93
Набережные Челны (8552)20-53-41
Нижний Новгород (831)429-08-12
Новокузнецк (3843)20-46-81
Новосибирск (383)227-86-73
Омск (3812)21-46-40
Орел (4862)44-53-42
Оренбург (3532)37-68-04
Пенза (8412)22-31-16
Россия (495)268-04-70

Пермь (342)205-81-47
Ростов-на-Дону (863)308-18-15
Рязань (4912)46-61-64
Самара (846)206-03-16
Санкт-Петербург (812)309-46-40
Саратов (845)249-38-78
Севастополь (8692)22-31-93
Симферополь (3652)67-13-56
Смоленск (4812)29-41-54
Сочи (862)225-72-31
Ставрополь (8652)20-65-13
Казахстан (772)734-952-31

Сургут (3462)77-98-35
Тверь (4822)63-31-35
Томск (3822)98-41-53
Тула (4872)74-02-29
Тюмень (3452)66-21-18
Ульяновск (8422)24-23-59
Уфа (347)229-48-12
Хабаровск (4212)92-98-04
Челябинск (351)202-03-61
Череповец (8202)49-02-64
Ярославль (4852)69-52-93